

**Model K-P1 Series**  
**(Machine Code: G058/G056)**  
**SERVICE MANUAL**

October 10th, 2000  
Subject to change

# **IMPORTANT SAFETY NOTICES**

## **PREVENTION OF PHYSICAL INJURY**

1. Before disassembling or assembling parts of the copier and peripherals, make sure that the printer power cord is unplugged.
2. The wall outlet should be near the printer and easily accessible.
3. Note that some components of the printer and the paper tray unit are supplied with electrical voltage even if the main power switch is turned off.
4. If any adjustment or operation check has to be made with exterior covers off or open while the main switch is turned on, keep hands away from electrified or mechanically driven components.
5. The inside and the metal parts of the fusing unit become extremely hot while the printer is operating. Be careful to avoid touching those components with your bare hands.

## **HEALTH SAFETY CONDITIONS**

Toner and developer are non-toxic, but if you get either of them in your eyes by accident, it may cause temporary eye discomfort. Try to remove with eye drops or flush with water as first aid. If unsuccessful, get medical attention.

## **OBSERVANCE OF ELECTRICAL SAFETY STANDARDS**

The printer and its peripherals must be installed and maintained by a customer service representative who has completed the training course on those models.

## SAFETY AND ECOLOGICAL NOTES FOR DISPOSAL

1. Do not incinerate toner bottles or used toner. Toner dust may ignite suddenly when exposed to an open flame.
2. Dispose of used toner, developer, and organic photoconductors in accordance with local regulations. (These are non-toxic supplies.)
3. Dispose of replaced parts in accordance with local regulations.

## LASER SAFETY

The Center for Devices and Radiological Health (CDRH) prohibits the repair of laser-based optical units in the field. The optical housing unit can only be repaired in a factory or at a location with the requisite equipment. The laser subsystem is replaceable in the field by a qualified Customer Engineer. The laser chassis is not repairable in the field. Customer engineers are therefore directed to return all chassis and laser subsystems to the factory or service depot when replacement of the optical subsystem is required.

### WARNING

**Use of controls, or adjustment, or performance of procedures other than those specified in this manual may result in hazardous radiation exposure.**

### WARNING

**WARNING: Turn off the main switch before attempting any of the procedures in the Laser Unit section. Laser beams can seriously damage your eyes.**

**CAUTION MARKING:**



G058R500.WMF

**Trademarks**

Microsoft<sup>®</sup>, Windows<sup>®</sup>, and MS-DOS<sup>®</sup> are registered trademarks of Microsoft Corporation in the United States and /or other countries.

PostScript<sup>®</sup> is a registered trademark of Adobe Systems, Incorporated.

PCL<sup>®</sup> is a registered trademark of Hewlett-Packard Company.

Ethernet<sup>®</sup> is a registered trademark of Xerox Corporation.

PowerPC<sup>®</sup> is a registered trademark of International Business Machines Corporation.

Other product names used herein are for identification purposes only and may be trademarks of their respective companies. We disclaim any and all rights involved with those marks.

# TABLE OF CONTENTS

<b>1. INSTALLATION .....</b>	<b>1-1</b>
1.1 INSTALLATION REQUIREMENTS .....	1-1
1.1.1 ENVIRONMENT .....	1-1
1.1.2 MACHINE LEVEL .....	1-1
1.1.3 MACHINE SPACE REQUIREMENT .....	1-1
1.1.4 POWER REQUIREMENTS .....	1-2
1.2 MACHINE INSTALLATION .....	1-2
1.3 OPTIONAL UNIT INSTALLATION .....	1-2
<b>2. PREVENTIVE MAINTENANCE .....</b>	<b>2-1</b>
2.1 USER MAINTENANCE .....	2-1
2.2 SERVICE MAINTENANCE .....	2-2
<b>3. REPLACEMENT AND ADJUSTMENT .....</b>	<b>3-1</b>
3.1 SPECIAL TOOLS .....	3-1
3.2 EXTERIOR COVERS .....	3-2
3.3 LASER UNIT .....	3-3
3.3.1 CAUTION DECAL LOCATIONS .....	3-3
3.3.2 POLYGON MIRROR MOTOR .....	3-4
3.3.3 LASER SYNCHRONIZATION DETECTOR .....	3-4
3.3.4 LASER UNIT .....	3-5
3.3.5 LASER DIODE UNIT .....	3-7
Laser beam pitch adjustment .....	3-8
3.4 TRANSFER ROLLER .....	3-9
3.5 TONER END SENSOR .....	3-9
3.6 FUSING .....	3-10
3.6.1 FUSING UNIT .....	3-10
3.6.2 HOT ROLLER AND FUSING LAMP .....	3-11
3.6.3 THERMISTOR AND THERMOSTAT .....	3-13
3.7 PAPER FEED .....	3-14
3.7.1 FEED ROLLER .....	3-14
3.7.2 FRICTION PAD .....	3-14
3.8 BY-PASS TRAY .....	3-15
3.8.1 BY-PASS TRAY UNIT AND BY-PASS FEED ROLLER .....	3-15
3.9 PRINTER CONTROLLER BOARD .....	3-16
3.10 ENGINE BOARD .....	3-16
3.11 MAIN MOTOR .....	3-17
3.12 SOLENOIDS AND CLUTCHES .....	3-17
3.13 POWER SUPPLY UNIT AND HIGH VOLTAGE SUPPLY BOARD .....	3-18
3.14 IMAGE ADJUSTMENT .....	3-19
3.14.1 REGISTRATION ADJUSTMENT .....	3-19
3.14.2 PARALLELOGRAM IMAGE ADJUSTMENT .....	3-19

<b>4. TROUBLESHOOTING .....</b>	<b>4-1</b>
4.1 SERVICE CALL CONDITIONS .....	4-1
4.1.1 SUMMARY .....	4-1
4.1.2 SC CODE DESCRIPTIONS .....	4-2
4.2 CONTROLLER ERROR .....	4-4
4.3 ELECTRICAL COMPONENT DEFECTS .....	4-6
4.3.1 SENSORS .....	4-6
4.3.2 SWITCHES.....	4-6
4.4 BLOWN FUSE CONDITIONS .....	4-7
4.5 LEDS .....	4-7
<b>5. SERVICE TABLES.....</b>	<b>5-1</b>
5.1 SERVICE PROGRAM MODE.....	5-1
5.1.1 ENABLING AND DISABLING SERVICE PROGRAM MODE .....	5-1
Entering the Service Mode.....	5-1
Accessing the Required Program .....	5-1
Inputting a Value or Setting for a Service Program.....	5-2
Exiting Service Mode .....	5-2
5.2 PRINTER CONTROLLER SERVICE MODE .....	5-3
5.2.1 SERVICE MODE MENU ('1. SERVICE MENU').....	5-3
5.2.2 BIT SWITCH PROGRAMMING .....	5-3
5.3 PRINTER ENGINE SERVICE MODE.....	5-4
5.3.1 SERVICE MODE TABLE ('2. ENGINE MAINTENANCE') .....	5-4
Memory Clear .....	5-8
5.3.2 INPUT CHECK TABLE .....	5-10
Table 1: Paper Size Switch (Main Unit) .....	5-11
Table 2: Paper Size Switch (optional paper tray).....	5-12
Table 3: Paper Height Sensor (standard cassette) .....	5-12
Table 4: Paper Height Sensor (optional paper tray).....	5-12
5.3.3 OUTPUT CHECK TABLE .....	5-13
5.4 FIRMWARE UPDATE PROCEDURE.....	5-14
5.4.1 CONTROLLER/NIB/ENGINE FIRMWARE UPDATE.....	5-14
5.4.2 ERROR RECOVERY.....	5-15
Controller .....	5-15
NIB/Engine Board .....	5-15
5.5 POWER-ON SELF TEST .....	5-16
5.6 OTHER TESTS .....	5-16
5.7 USER PROGRAM MODE .....	5-17
5.8 DIP SWITCHES.....	5-18
Controller Board.....	5-18
Engine Board .....	5-18

<b>6. DETAILED SECTION DESCRIPTIONS .....</b>	<b>6-1</b>
6.1 OVERVIEW .....	6-1
6.1.1 MECHANICAL COMPONENT LAYOUT .....	6-1
6.1.2 PAPER PATH .....	6-2
6.2 BOARD STRUCTURE .....	6-3
6.2.1 OVERVIEW .....	6-3
6.2.2 DESCRIPTIONS .....	6-4
6.2.3 CONTROLLER BOARD .....	6-5
6.3 PRINTING PROCESS .....	6-6
6.3.1 OVERVIEW .....	6-6
6.3.2 LASER EXPOSURE .....	6-7
Overview .....	6-7
Automatic Power Control (APC) .....	6-8
LD Safety Mechanisms .....	6-9
6.3.3 CARTRIDGE OVERVIEW .....	6-10
6.3.4 DRUM CHARGE .....	6-10
6.3.5 DEVELOPMENT .....	6-11
Overview .....	6-11
Toner Supply .....	6-11
Development Unit .....	6-11
Toner Density Control .....	6-12
Development Bias .....	6-12
Toner End Detection .....	6-13
6.3.6 IMAGE TRANSFER AND PAPER SEPARATION .....	6-14
Overview .....	6-14
Transfer Roller Cleaning .....	6-14
6.3.7 CLEANING .....	6-15
6.3.8 QUENCHING .....	6-15
6.3.9 ID CHIP .....	6-16
6.4 PAPER FEED .....	6-17
6.4.1 OVERVIEW .....	6-17
Paper Tray .....	6-17
By-pass Tray .....	6-17
6.4.2 PAPER TRAY .....	6-18
Tray Extension .....	6-18
Paper Lift .....	6-18
Paper Feed and Registration .....	6-19
Paper Size Detection .....	6-20
Paper End/Paper Near-end Detection .....	6-20
6.4.3 BY-PASS TRAY .....	6-21
6.5 IMAGE FUSING AND PAPER EXIT .....	6-22
6.5.1 OVERVIEW .....	6-22
6.5.2 FUSING DRIVE .....	6-22
6.5.3 FUSING ENTRANCE GUIDE SHIFT .....	6-23
6.5.4 PRESSURE ROLLER .....	6-23
6.5.5 NEW FUSING UNIT DETECTION .....	6-24
6.5.6 FUSING TEMPERATURE CONTROL .....	6-25
6.5.7 PAPER EXIT .....	6-26

6.5.8 ENERGY SAVER MODE.....	6-27
Entering Energy Saver Mode.....	6-27
Leaving Energy Saver Mode.....	6-27
6.6 CONTROLLER FUNCTIONS .....	6-28
6.6.1 METER-CHARGE MODE.....	6-28
Meter-charge Counter Display.....	6-28
PM Warning Display .....	6-28
6.6.2 SAMPLE PRINT .....	6-28
6.6.3 LOCKED PRINT .....	6-29
6.6.4 PAPER SOURCE SELECTION.....	6-29
Tray Priority (Auto Tray Select).....	6-29
Tray Lock.....	6-29
Manual Tray Select.....	6-29
6.6.5 AUTO CONTINUE .....	6-30
Auto Tray Select .....	6-30
Manual Tray Select.....	6-30
6.6.6 PAPER OUTPUT TRAY .....	6-31
Output Tray Selected.....	6-31
Auto Tray Switching.....	6-31
6.7 NIB .....	6-32
6.7.1 BLOCK DIAGRAM.....	6-32
6.7.2 LED INDICATORS.....	6-32
6.8 IEEE1394 INTERFACE .....	6-33
6.8.1 SPECIFICATIONS.....	6-33
Hardware Specification .....	6-33
System Requirements.....	6-33
6.8.2 IEEE1394 .....	6-33
6.8.3 BLOCK DIAGRAM.....	6-34
6.8.4 PIN ASSIGNMENT .....	6-34
6.8.5 REMARKS ABOUT THIS INTERFACE KIT.....	6-35
6.8.6 TROUBLESHOOTING NOTES .....	6-35

<b>SPECIFICATIONS.....</b>	<b>1</b>
1. GENERAL SPECIFICATIONS.....	1
1.1 SUPPORTED PAPER SIZES.....	3
2. SOFTWARE ACCESSORIES .....	4
2.1 PRINTER DRIVERS.....	4
2.2 UTILITY SOFTWARE .....	4
3. MACHINE CONFIGURATION.....	5
3.1 SYSTEM COMPONENTS .....	5
4. OPTIONAL EQUIPMENT .....	6
4.1 PAPER TRAY UNIT.....	6
4.2 ENVELOPE FEEDER.....	6
4.3 DUPLEX UNIT.....	6
4.4 FOUR-BIN MAILBOX .....	7
4.5 ONE-BIN SHIFT TRAY.....	7



# PERIPHERALS

## PAPER TRAY UNIT (G555)/ENVELOPE FEEDER (G556)

<b>1. REPLACEMENT AND ADJUSTMENT.....</b>	<b>1-1</b>
1.1 PAPER FEED UNIT .....	1-1
1.2 PAPER FEED ROLLER .....	1-2
1.3 FRICTION PAD .....	1-2
<b>2. DETAILED DESCRIPTIONS .....</b>	<b>2-1</b>
2.1 OVERALL MACHINE INFORMATION .....	2-1
2.1.1 MECHANICAL COMPONENT LAYOUT.....	2-1
2.1.2 ELECTRICAL COMPONENT LAYOUT .....	2-1
2.2 DETAILED SECTION DESCRIPTIONS .....	2-2
2.2.1 PAPER FEED AND SEPARATION .....	2-2
2.2.2 PAPER LIFT .....	2-3
2.2.3 PAPER END DETECTION .....	2-3
2.2.4 PAPER HEIGHT DETECTION .....	2-4
2.2.5 PAPER SIZE DETECTION.....	2-5
<b>3. ENVELOPE FEEDER.....</b>	<b>3-1</b>
3.1 OVERALL MACHINE INFORMATION .....	3-1
3.1.1 MECHANICAL COMPONENT LAYOUT.....	3-1

## DUPLEX UNIT (G552)

<b>1. REPLACEMENT AND ADJUSTMENT.....</b>	<b>1-1</b>
1.1 EXTERIOR COVERS.....	1-1
1.2 DUPLEX BOARD AND SENSORS .....	1-2
<b>2. DETAILED DESCRIPTION .....</b>	<b>2-1</b>
2.1 OVERALL MACHINE INFORMATION .....	2-1
2.1.1 MECHANICAL COMPONENT LAYOUT.....	2-1
2.1.2 DRIVE LAYOUT .....	2-2
2.1.3 ELECTRICAL COMPONENT LAYOUT .....	2-2
2.2 DETAILED SECTION DESCRIPTIONS .....	2-3
2.2.1 BASIC OPERATION.....	2-3
Longer than A4 LEF/LT LEF .....	2-3
Length up to A4 LEF/LT LEF .....	2-4
2.2.2 FEED IN AND EXIT MECHANISM .....	2-5
Feeding paper into the duplex unit:.....	2-5
Inversion and exit:.....	2-5

## **FOUR-BIN MAILBOX (G553)**

<b>1. REPLACEMENT AND ADJUSTMENT.....</b>	<b>1-1</b>
1.1 EXTERIOR COVERS .....	1-1
1.2 OVERFLOW AND VERTICAL TRANSPORT SENSORS .....	1-2
1.3 MAIN MOTOR .....	1-3
<b>2. DETAILED DESCRIPTIONS .....</b>	<b>2-1</b>
2.1 OVERALL MACHINE INFORMATION .....	2-1
2.1.1 MECHANICAL COMPONENT LAYOUT.....	2-1
2.1.2 DRIVE LAYOUT .....	2-2
2.1.3 ELECTRICAL COMPONENT LAYOUT .....	2-3
2.2 DETAILED SECTION DESCRIPTIONS .....	2-4
2.2.1 BASIC OPERATION.....	2-4

## **ONE-BIN SHIFT TRAY (G554)**

<b>1. REPLACEMENT AND ADJUSTMENT.....</b>	<b>1-1</b>
1.1 EXTERIOR COVERS .....	1-1
1.2 SHIFT TIMING AND TRAY PAPER SENSORS .....	1-2
1.3 COVER AND OVERFLOW SENSORS .....	1-2
1.4 MAIN MOTOR .....	1-3
<b>2. DETAILED DESCRIPTIONS .....</b>	<b>2-1</b>
2.1 OVERALL MACHINE INFORMATION .....	2-1
2.1.1 MECHANICAL COMPONENT LAYOUT.....	2-1
2.1.2 DRIVE LAYOUT .....	2-1
2.1.3 ELECTRICAL COMPONENT LAYOUT .....	2-2
2.2 DETAILED SECTION DESCRIPTIONS .....	2-3
2.2.1 BASIC OPERATION.....	2-3
2.2.2 SORT MODE OPERATION.....	2-3

# 1. INSTALLATION

## 1.1 INSTALLATION REQUIREMENTS

### 1.1.1 ENVIRONMENT

1. Temperature Range: 10 °C to 32 °C (50 °F to 89.6 °F)
2. Humidity Range: 15 % to 80 % RH
3. Ambient Illumination: Less than 2,000 lux (do not expose to direct sunlight).
4. Ventilation: 3 times/hr/person
5. Avoid areas which are exposed to sudden temperature changes. This includes:
  - 1) Areas directly exposed to cool air from an air conditioner.
  - 2) Areas directly exposed to heat from a heater.
6. Do not place the machine in an area where it will be exposed to corrosive gases.
7. Do not install the machine at any location over 2,500 m (8,125 ft.) above sea level.
8. Place the machine on a strong and level base. (Inclination on any side should be no more than 5 mm.)
9. Do not place the machine where it may be subjected to strong vibrations.

### 1.1.2 MACHINE LEVEL

Front to back: Within 5 mm (0.2") of level

Right to left: Within 5 mm (0.2") of level

### 1.1.3 MACHINE SPACE REQUIREMENT

Place the machine near the power source, providing clearance as shown.

A: Over 10 cm (4")

B: Over 10 cm (4")

C: Over 100 cm (40")

D: Over 10 cm (4")

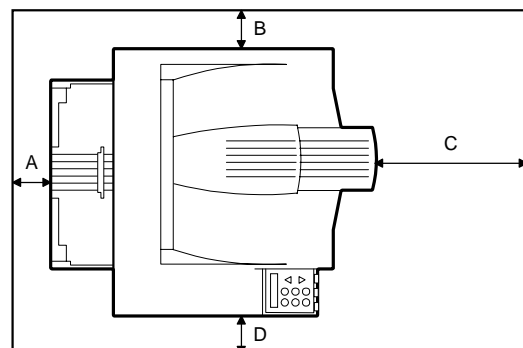

G0561500.WMF

### 1.1.4 POWER REQUIREMENTS

<b>⚠ CAUTION</b>
------------------

- |   |
|---|
| <ol style="list-style-type: none"><li>1. <b>Make sure the plug is firmly inserted in the outlet.</b></li><li>2. <b>Avoid multi-wiring.</b></li><li>3. <b>Be sure to ground the machine.</b></li></ol> |
|---|

1. Input voltage level: 120 V, 60 Hz: More than 10 A  
220 V ~ 240 V, 50 Hz/60 Hz: More than 6 A
2. Permissible voltage fluctuation:  $\pm 10\%$
3. Do not set anything on the power cord.

## 1.2 MACHINE INSTALLATION

Refer to the Operating Instructions for details.

## 1.3 OPTIONAL UNIT INSTALLATION

The following options are available for this machine. Refer to the Operating Instructions for how to install these options.

- Paper Tray Unit
- 4-bin Mailbox
- 1-bin Shift Tray
- Duplex Unit
- Envelope Feeder
- NIB (G056 only) - the NIB is a standard component for the G058
- Hard disk
- IEEE1394 (G056/G058 - to install in the G058, the NIB must be removed first)
- 64-MB DIMM

## 2. PREVENTIVE MAINTENANCE

### 2.1 USER MAINTENANCE

All PM items can be done by the customer, using the maintenance kit. The maintenance kit contains the following items.

Meter-charge mode must be set to 'disabled' (controller service mode).

**Cross-reference:** Section 5.3 Engine service mode

When the PM counter reaches 90K, "Replace Maintenance Kit" is displayed. After the user replaces the fusing unit in the maintenance kit, the machine automatically resets the PM counter.

Item	Quantity	Remarks
Fusing unit	1	
Transfer roller	1	
Paper feed roller for the standard tray	1	
Paper feed rollers for the optional PFU	2	Optional paper tray unit
Friction pad - standard tray	1	
Friction pads - optional trays	2	Optional paper tray unit

## 2.2 SERVICE MAINTENANCE

The following tables list the PM items when the PM is done by service.

- NOTE:** 1) You must switch on meter-charge mode in printer engine service mode to disable the user's PM warning.  
 2) After completing PM, make sure to reset the PM counter using the printer engine service mode "PM Counter Reset".

Symbol key: C: Clean, R: Replace, L: Lubricate, I: Inspect

### Main unit

Item	90K	EM	Remarks
<b>Paper Feed</b>			
Paper Feed Roller	R	C	Clean with water
Friction Pad	R	C	Clean with water
Registration Mylar	C	C	Clean with water
<b>Around the Drum</b>			
Transfer Roller	R		
<b>Fusing Unit and Paper Exit</b>			
Hot Roller	R		
Pressure Roller	R		
Hot Roller Strippers	R		
Fusing Thermistor	R	C	Clean with alcohol if necessary.
Bushing - Fusing Roller	R		
Bushing - Fusing Pressure	R		
Fusing Entrance and Exit Guide Plates	C		Clean with water or alcohol

### Paper Tray Unit

	90K	EM	NOTE
Paper Feed Roller	R	C	Clean with water
Friction Pad	R	C	Dry cloth
Bottom Plate Pad	C	C	Clean with water

### Four-bin Mailbox

	90K	EM	NOTE
Exit Rollers		C	Clean with water
Driven Rollers		C	Clean with water
Trays		C	Clean with water

### One-bin Shift Tray

	90K	EM	NOTE
Exit Rollers		C	Clean with water
Driven Rollers		C	Clean with water
Transport Rollers		C	Clean with water
Paper Tray		C	Clean with water
Tray Paper Sensor		C	Clean with water

## 3. REPLACEMENT AND ADJUSTMENT

### CAUTION

Turn off the main power switch and unplug the machine before attempting any of the procedures in this section.

**NOTE:** This manual uses the following symbols.

 : See or Refer to

 : Screws

 : Connector

### 3.1 SPECIAL TOOLS

Part Number	Description	Described Section	Q'ty
A0069104	Scanner Positioning Pin (4 pcs/set)	3.3	1
A2309352	Flash Memory Card - 4MB	5.4	1
G0219350	Loop-back connector - parallel	5.5	1

### 3.2 EXTERIOR COVERS

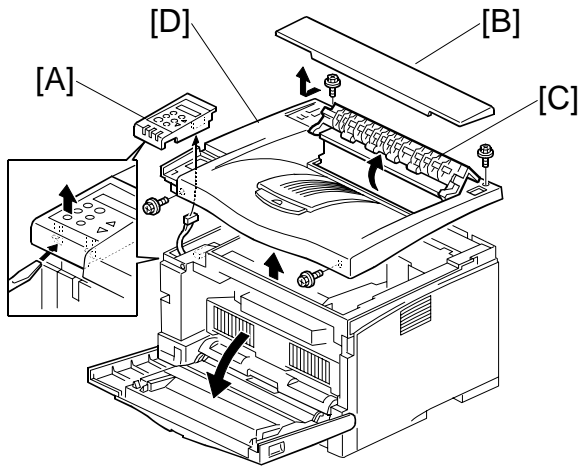

G058R201.WMF

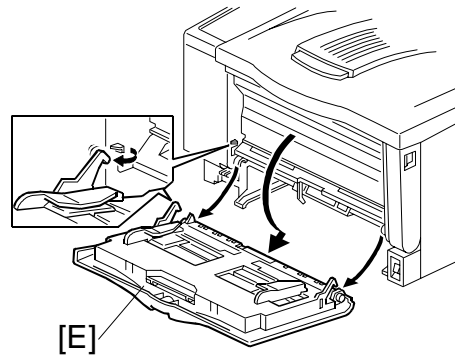

G058R701.WMF

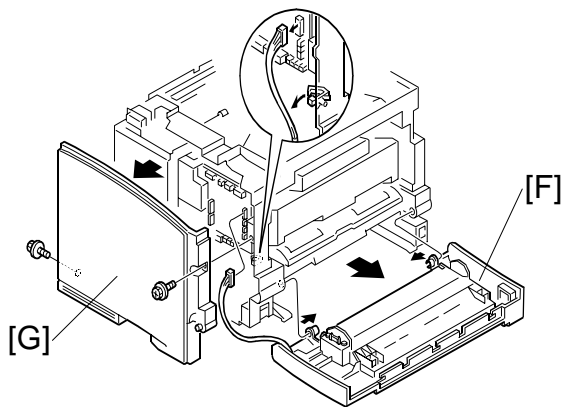



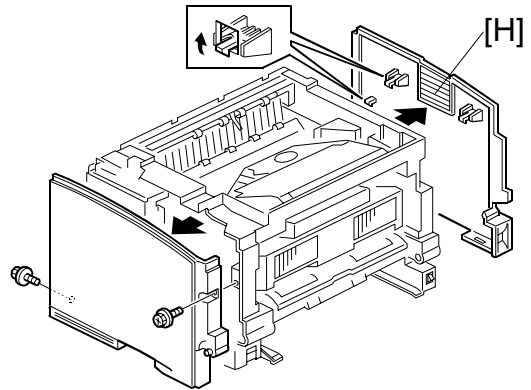

G058R702.WMF



G058R703.WMF

To remove the left or right cover, separate the machine from the optional paper tray unit first.

Open the front cover.

- [A]: Operation panel (2 hooks,  x1)
- [B]: Upper exit cover
- [C]: Open the exit guide plate.
- [D]: Upper cover ( x4)
- [E]: By-pass tray unit (2 hooks)
- [F]: Front cover (3 hooks,  x1)
- [G]: Left cover ( x2)
- [H]: Right cover (3 hooks)



### 3.3 LASER UNIT

<b>⚠ WARNING</b>
<b>Turn off the main power switch and unplug the machine before attempting any of the procedures in this section. Laser beams can seriously damage your eyes.</b>

#### 3.3.1 CAUTION DECAL LOCATIONS

The caution decal is located in the laser section as shown below.

Replacement  
Adjustment

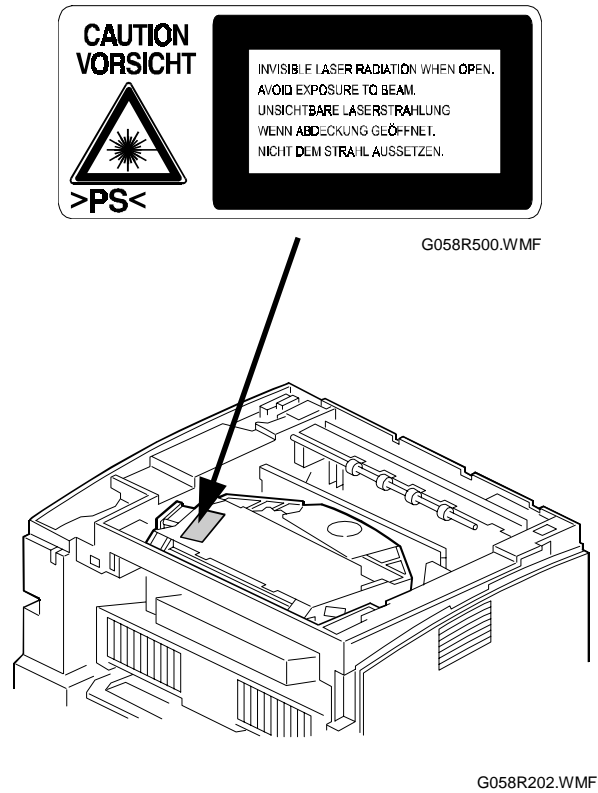

### 3.3.2 POLYGON MIRROR MOTOR

#### **⚠ WARNING**

Turn off the main switch and unplug the machine before attempting any of the procedures in this section. Laser beams can seriously damage your eyes.

Operation panel (☛ 3.2 Exterior Covers)

Upper cover (☛ 3.2 Exterior Covers)

[A]: Polygon mirror cover (🔩 x2)

[B]: Polygon mirror motor  
(🔩 x4, 📏 x1)

**NOTE:** Do not touch the surface of the mirror with bare hands.

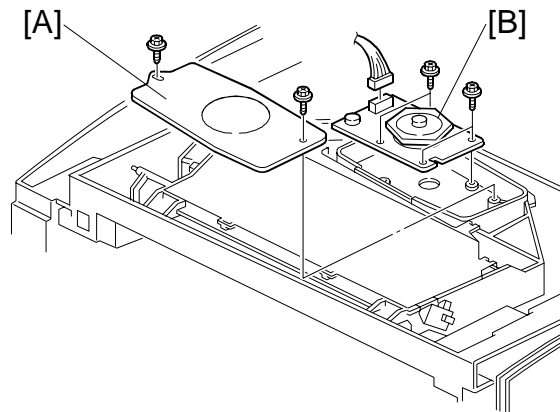

G058R204.WMF

### 3.3.3 LASER SYNCHRONIZATION DETECTOR

Operation panel (☛ 3.2 Exterior Covers)

Upper cover (☛ 3.2 Exterior Covers)

[A]: Laser synchronization detector (📏 x1)

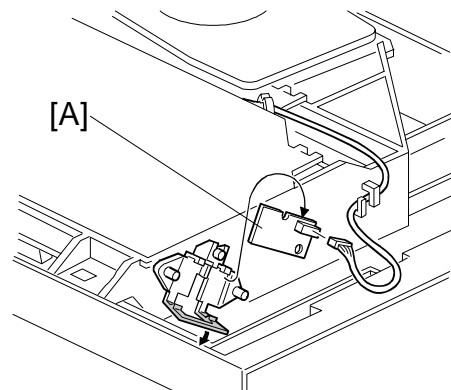

G058R206.WMF

### 3.3.4 LASER UNIT

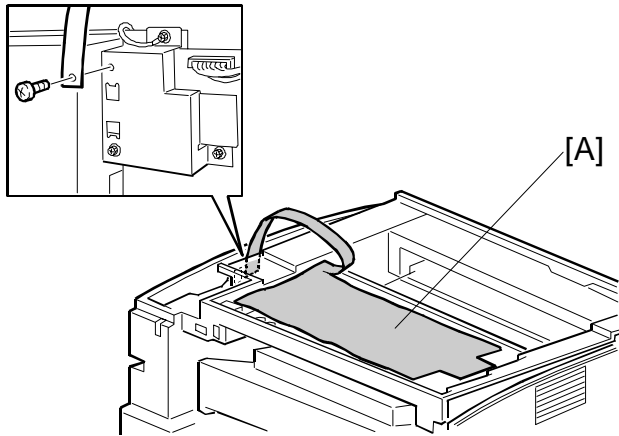

G058R730.WMF

Replacement  
Adjustment

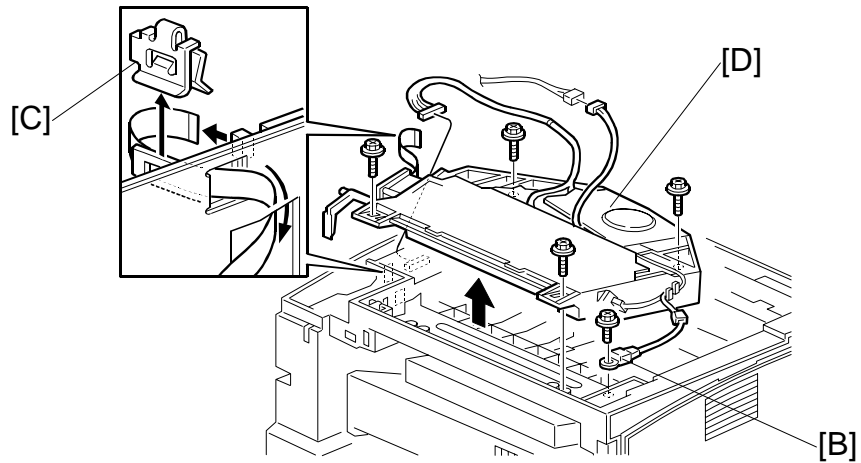

G058R203.WMF

Operation panel (☛ 3.2 Exterior Covers)

Upper cover (☛ 3.2 Exterior Covers)

Left cover (☛ 3.2 Exterior Covers)

[A]: **230V machine only:** Sheet (🔩 x1)

[B]: Thermistor (🔩 x1)

[C]: Clip

[D]: Laser unit (🔩 x4, 1 flat cable, 📡 x2)

**When reinstalling the laser unit**

Use the scanner positioning pin (P/N: A0069104) to reinstall the unit.

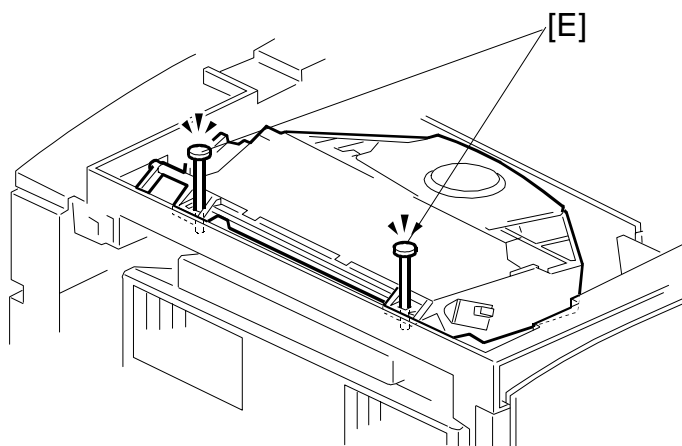

G058R208.WMF

[E]: Set the positioning pins as shown above. Then secure the laser unit.



### 3.3.5 LASER DIODE UNIT

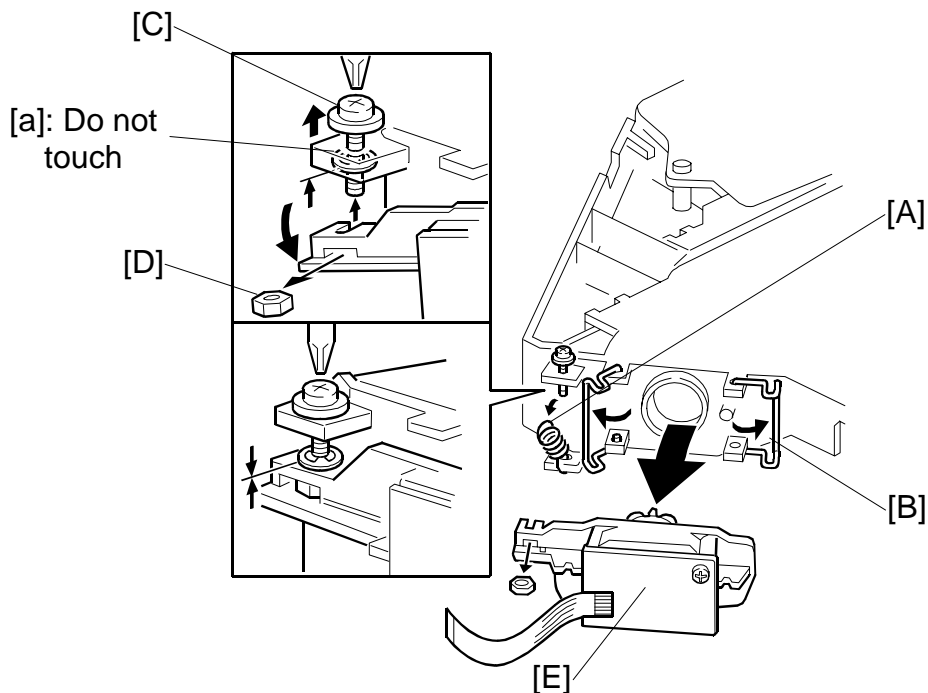

Replacement  
Adjustment

Laser unit (☛ 3.3.4 Laser Unit)

[A]: Spring

[B]: LD unit holders

[C]: Loosen the screw

**NOTE:** Do not loosen the E-ring [a]. This is because the position of this E-ring determines the LD unit position.

[D]: Nut

[E]: LD unit

**NOTE:** 1) Do not remove the screws that secure the LD board.

2) Do not touch any variable resistors on the LD board.

#### When installing the LD unit:

Tighten the screw [C] until the E-ring [a] touches the LD unit holder.

After installing the LD unit, check the test pattern for the final adjustment (see the following procedure).

***Laser beam pitch adjustment***

1. Print out the following test patterns – cross-stitch pattern and grid pattern.
2. Check these test patterns. If the laser beam pitch is not correct, the images are as follows.
  - Cross-stitch pattern: Vertical black strips seem to appear.
  - Grid pattern: The density of the diagonal lines is light or the lines have disappeared.
3. Adjust the LD unit holder position: Tighten or loosen the screw [C] (see the previous page) until the printout appears as follows.
  - Cross-stitch pattern: The thin lines are of uniform thickness (no striping effect should appear on the printout).
  - Grid pattern: The diagonal lines appear clearly and are of normal density.

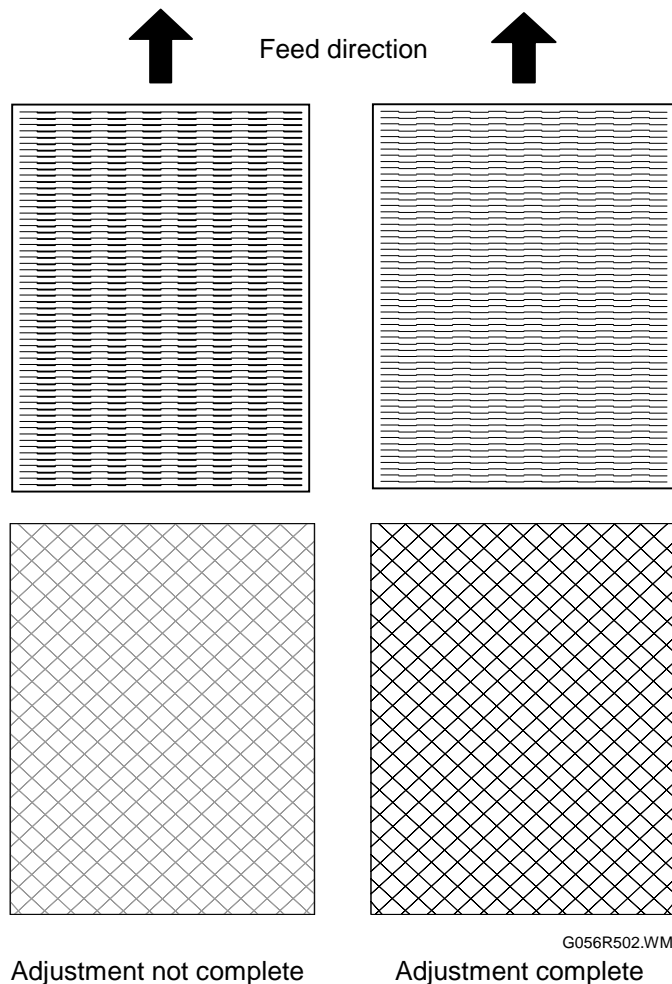

### 3.4 TRANSFER ROLLER

Cartridge

[A]: Transfer roller

**NOTE:** Do not touch the transfer roller surface.

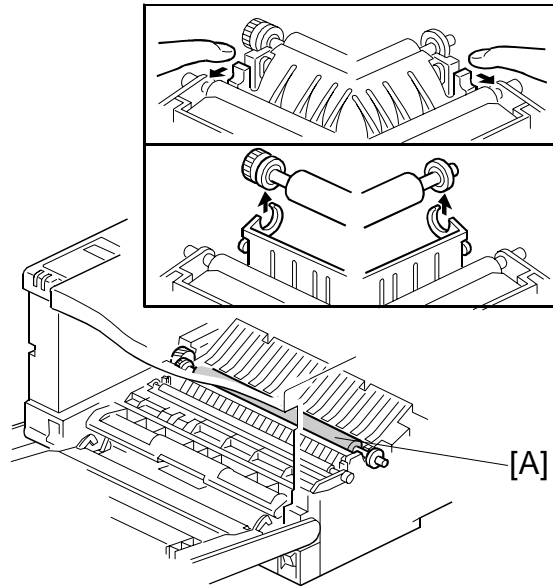

Replacement  
Adjustment

G058R401.WMF

### 3.5 TONER END SENSOR

Cartridge

[A]: Toner end sensor (4 hooks,  x1)

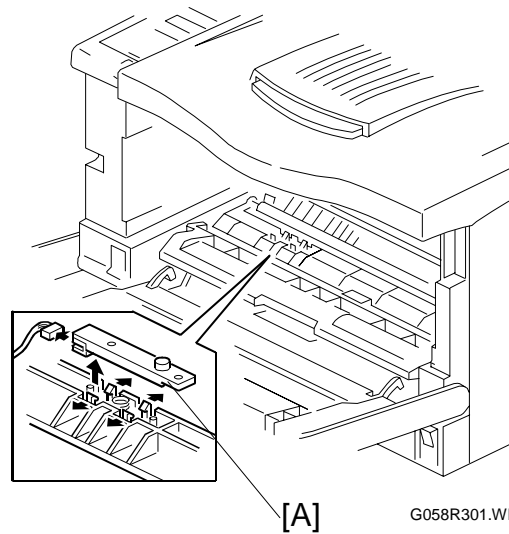

G058R301.WMF

### 3.6 FUSING

#### 3.6.1 FUSING UNIT

**⚠ CAUTION**  
Allow time for the unit to cool before doing the following procedure.

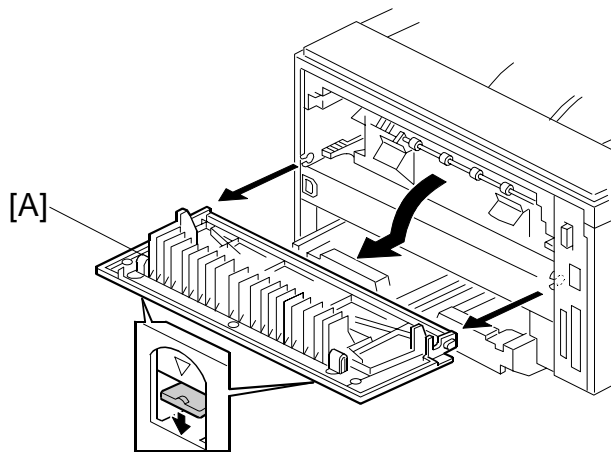

G058R501.WMF

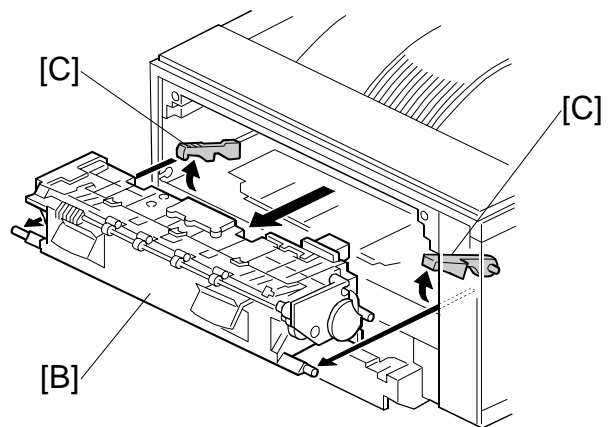

G058R502.WMF

- [A]: Exit cover
- [B]: Fusing unit (lift hooks [C])



### 3.6.2 HOT ROLLER AND FUSING LAMP

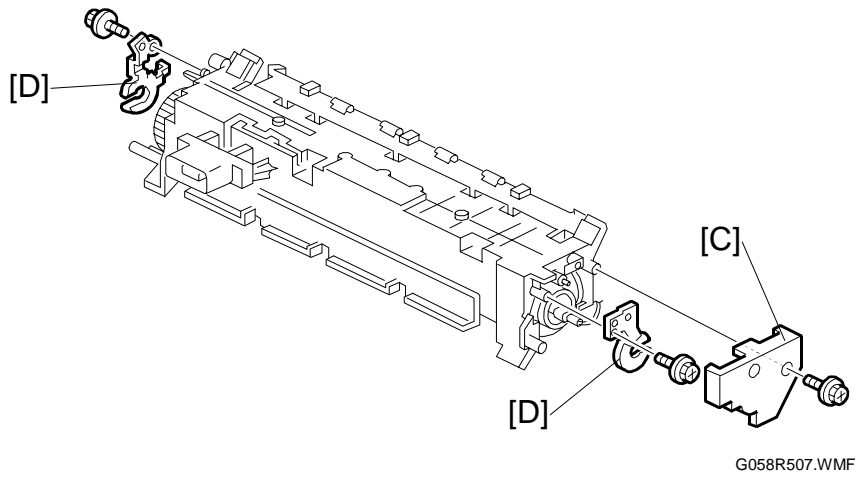
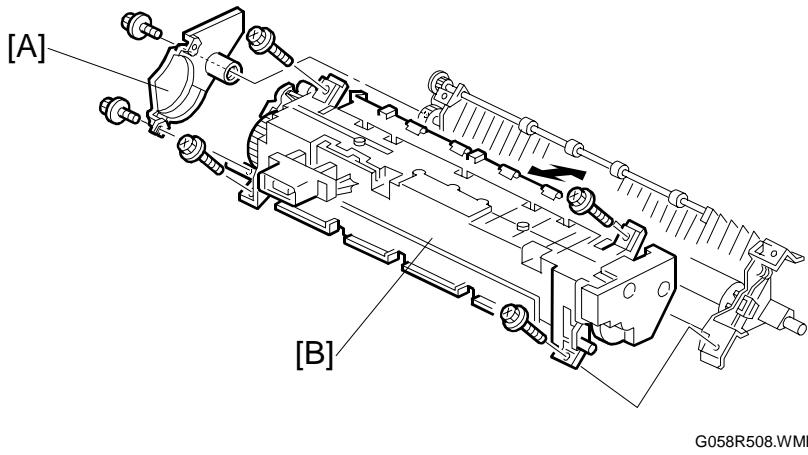

Replacement  
Adjustment

Fusing unit (☛ 3.6.1 Fusing Unit)

- [A]: Right cover (🔩 x2)
- [B]: Upper fusing unit assembly (🔩 x4)
- [C]: Left cover (🔩 x1)
- [D]: Lamp holders (🔩 x1 each)

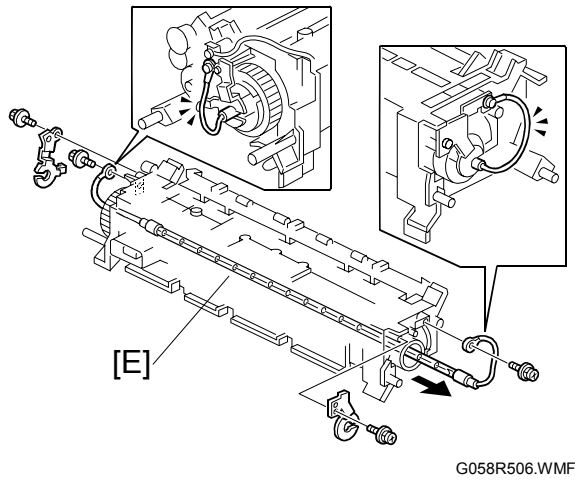

G058R506.WMF

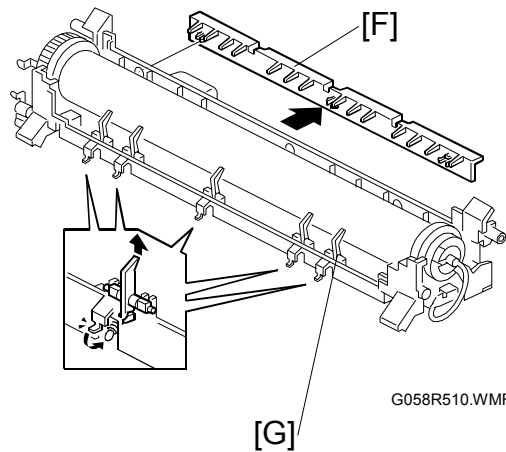

G058R510.WMF

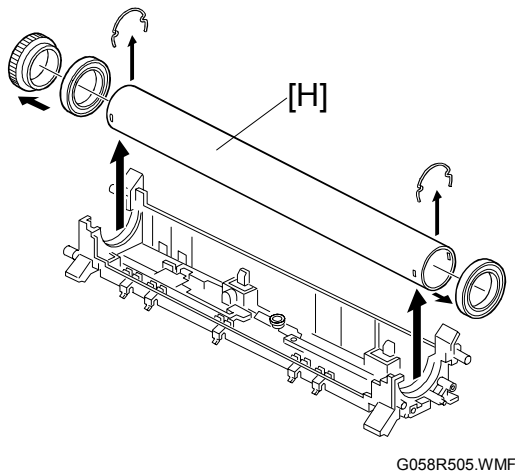

G058R505.WMF

[E]: Fusing lamp (  x2)

**NOTE:** The shorter cable must be at the hot roller gear side.

[F]: Guide plate (3 hooks)

[G]: Hot roller strippers (1 spring each)

[H]: Hot roller (2 C-rings, 1 gear, 2 bushings).

**NOTE:** Before installing the new hot roller, peel off 3 cm (1 inch) from both ends of the protective sheet on the new roller. Also, remove the rest of the paper before starting the machine.

### 3.6.3 THERMISTOR AND THERMOSTAT

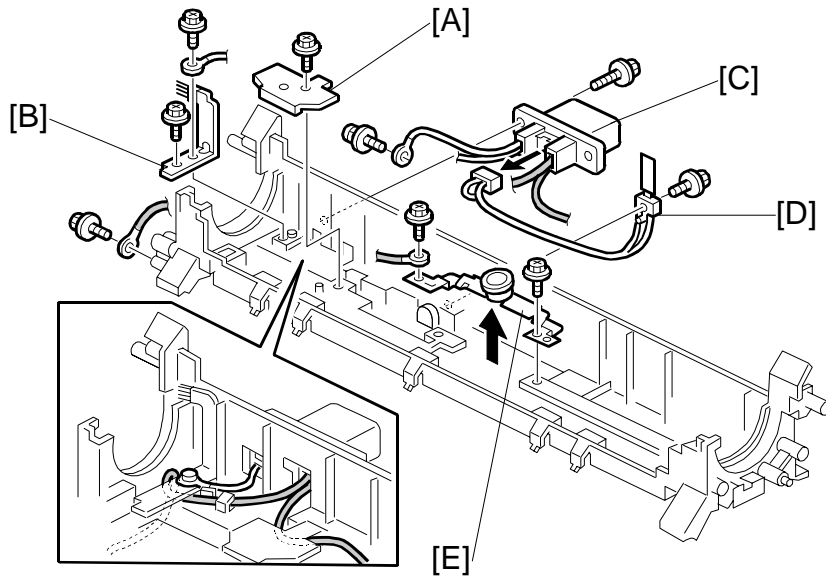

G058R503.WMF

Replacement  
Adjustment

Hot roller (☛ 3.6.2 Hot Roller and Fusing Lamp)

- [A]: Wire cover (🔩 x1)
- [B]: Grounding plate (🔩 x1, 1 wire)
- [C]: Fusing unit connector (🔩 x3, 📡 x1))
- [D]: Thermistor (🔩 x1)
- [E]: Thermostat (🔩 x1)

### 3.7 PAPER FEED

#### 3.7.1 FEED ROLLER

Paper Tray

[A]: Paper feed roller

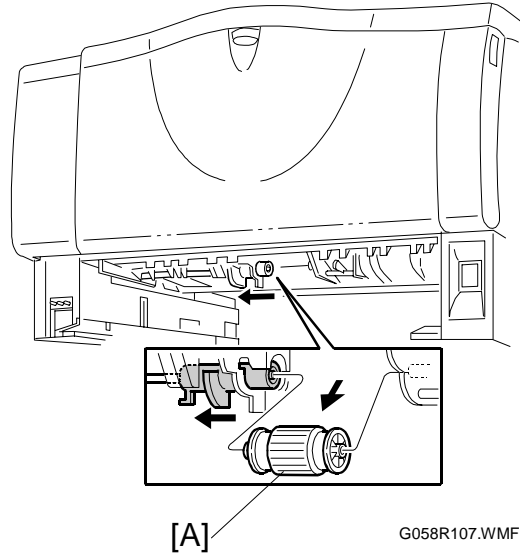

#### 3.7.2 FRICTION PAD

Paper Tray

[A]: Friction pad (2 hooks, 1 spring)

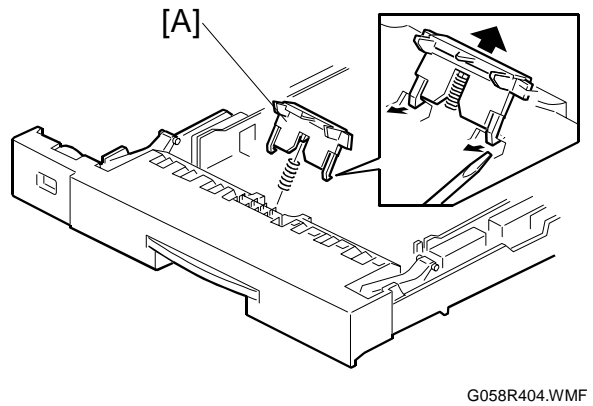

### 3.8 BY-PASS TRAY

#### 3.8.1 BY-PASS TRAY UNIT AND BY-PASS FEED ROLLER

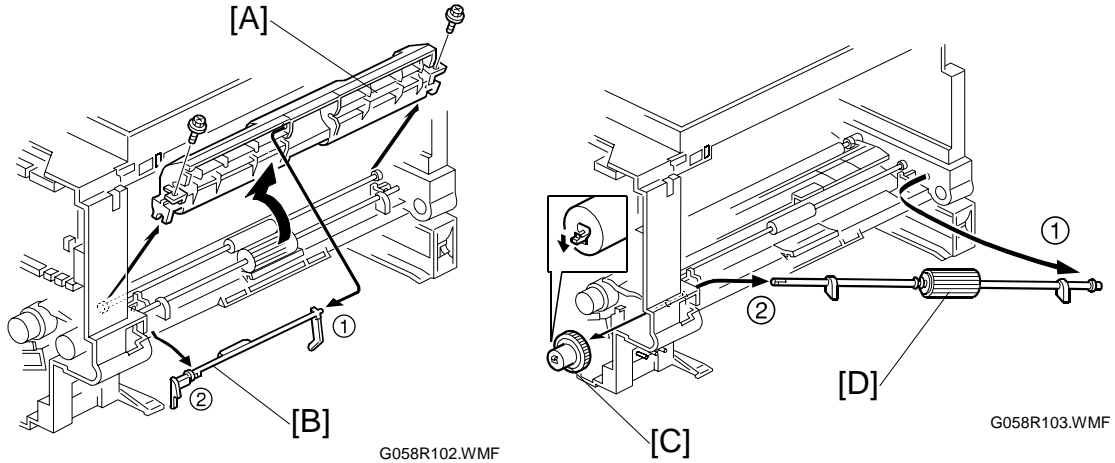

Replacement  
Adjustment

By-pass tray unit (☛ 3.2 Exterior Covers)

Front cover (☛ 3.2 Exterior Covers)

Cartridge

[A]: Paper guide (⚙ x2)

[B]: Actuator

[C]: Gear (1 hook)

[D]: By-pass feed roller

#### When reinstalling the paper guide:

- 1) Set the paper guide on the bushing.
- 2) Install the left part of the actuator in the machine.
- 3) Install the right part of the actuator on the paper guide.
- 4) Install the paper guide.
- 5) Make sure that the actuator moves smoothly.

### 3.9 PRINTER CONTROLLER BOARD

[A]: Printer controller board (🔩 x2)

**NOTE:** Remove the NVRAM [B] from the old printer controller board and put it on the new board.

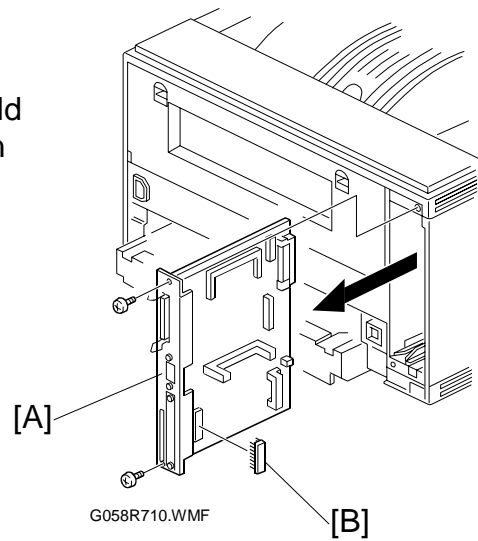

### 3.10 ENGINE BOARD

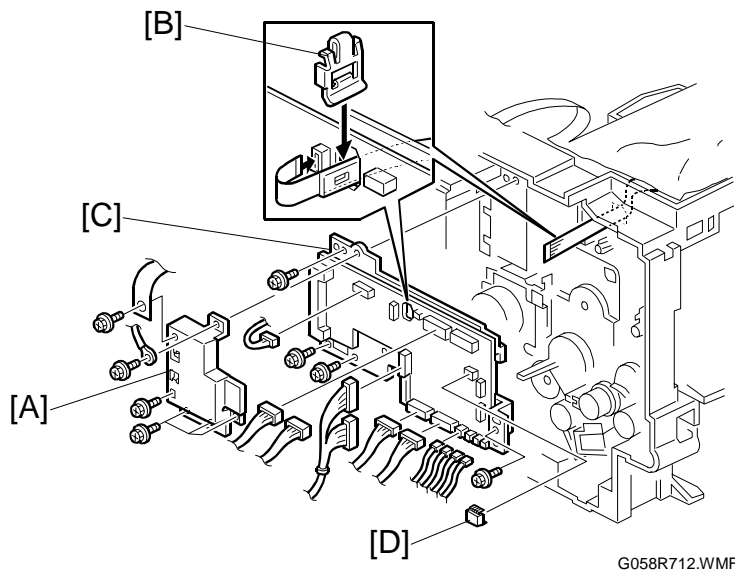

Left cover (☛ 3.2 Exterior Covers)

Printer controller board (☛ 3.9 Printer Controller Board)

[A]: Bracket (🔩 x6, 1 grounding wire)

**NOTE:** The sheet is used for 230V machine only.

[B]: Clip

[C]: Engine board (🔩 x5, all connectors)

**NOTE:** Remove the NVRAM [D] from the old engine board and put it on the new board.

### 3.11 MAIN MOTOR

Left cover (☛ 3.2 Exterior Covers)

[A]: Main motor (🔩 x4, 🛠️ x1)

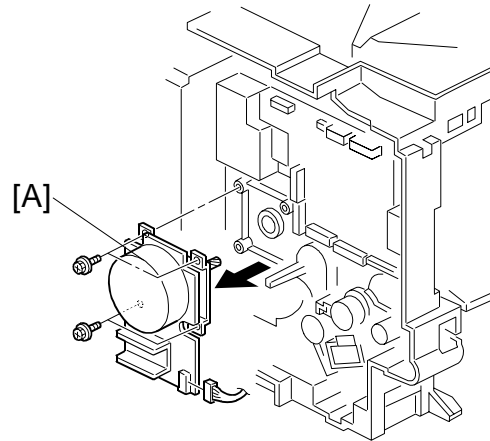

G058R711.WMF

Replacement Adjustment

### 3.12 SOLENOIDS AND CLUTCHES

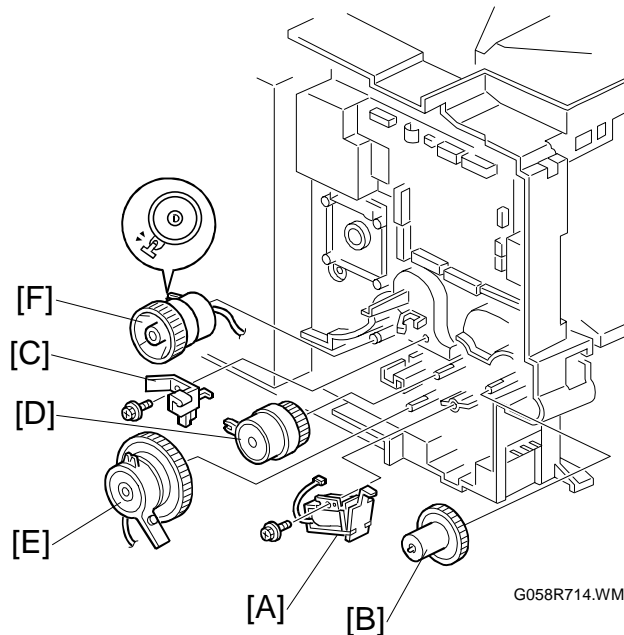

G058R714.WMF

Left cover (☛ 3.2 Exterior Covers)

[A]: By-pass feed solenoid (🔩 x1, 🛠️ x1)

[B]: Gear (1 hook)

[C]: Stopper (🔩 x1)

[D]: Relay clutch (1 hook, 🛠️ x1)

[E]: Paper feed clutch (1 hook, 🛠️ x1)

Main motor (☛ 3.11 Main Motor)

[F]: Registration clutch (🔩 x1, 🛠️ x1)

### 3.13 POWER SUPPLY UNIT AND HIGH VOLTAGE SUPPLY BOARD

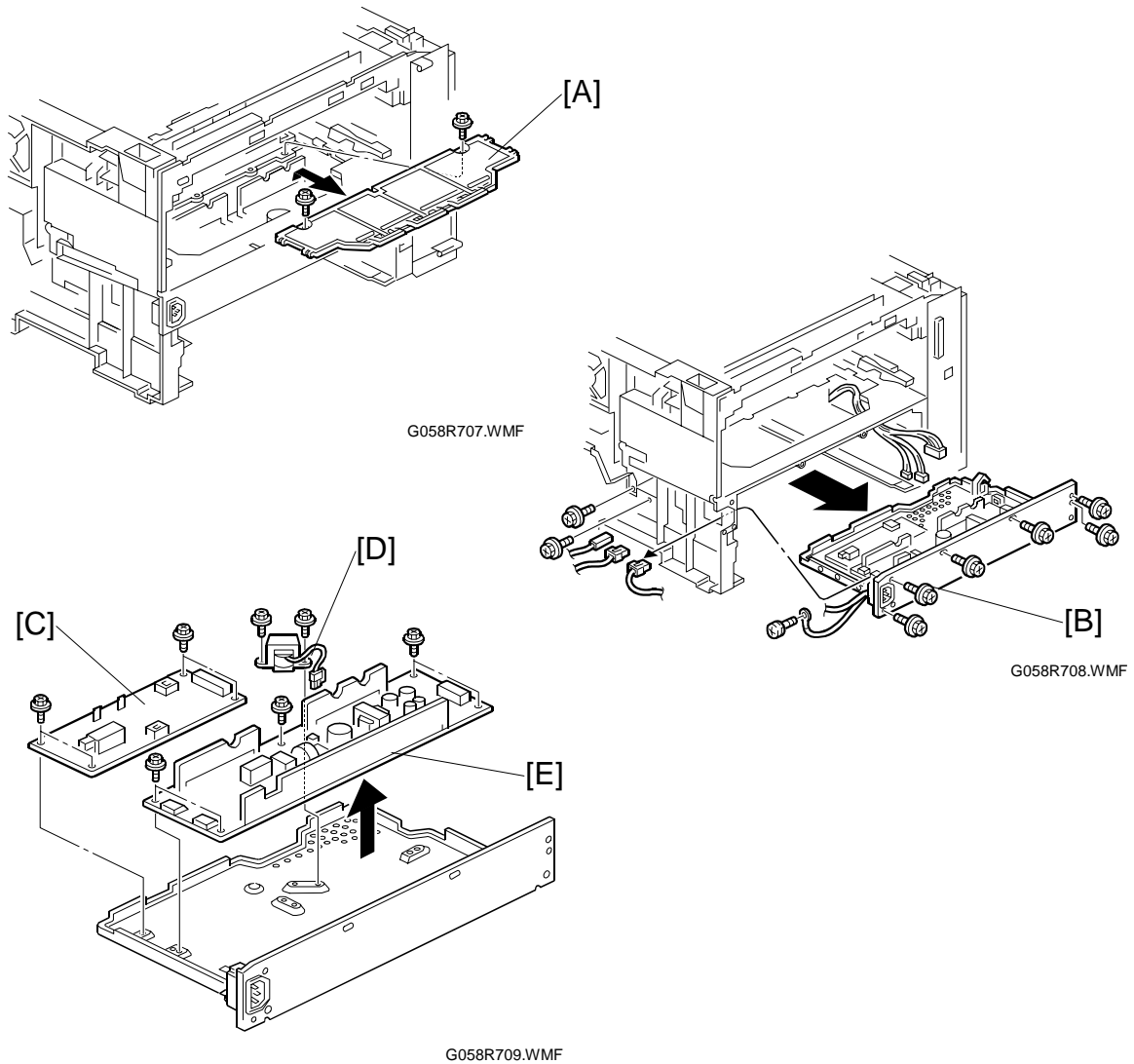

Left cover (☛ 3.2 Exterior Covers)

Fusing unit (☛ 3.6.1 Fusing Unit)

[A]: PSU cover (⚙ x2)

[B]: PSU assembly (⚙ x9, all connectors)

[C]: High voltage supply board (⚙ x4)

[D]: **230V machine only:** Choke coil (⚙ x2, ⚙ x1)

[E]: Power supply unit (⚙ x5)



## 3.14 IMAGE ADJUSTMENT

### 3.14.1 REGISTRATION ADJUSTMENT

The registration is adjusted using the user mode; "Maintenance-Registration-Adjustment"

### 3.14.2 PARALLELOGRAM IMAGE ADJUSTMENT

**NOTE:** Use the scanner positioning pin (P/N: A0069104) for the adjustment. Do the following procedure if a parallelogram is printed while adjusting the printing registration using a trimming pattern.

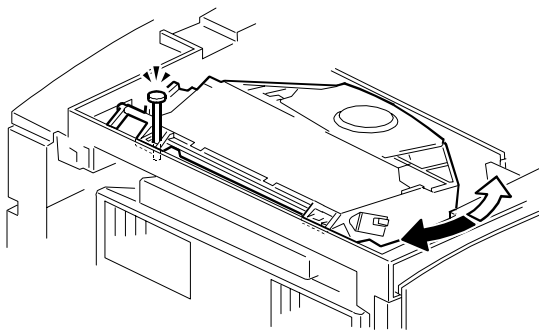

G058R210.WMF

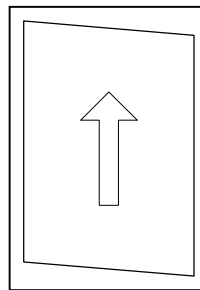

(a)

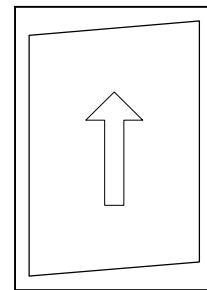

(b)

G056R500.WMF

Replacement  
Adjustment

1. Remove the upper cover (☛ 3.2 Exterior Covers)
2. Set a positioning pin to one of the hole (The above illustration explains when the image (a) is printed out).
3. Loosen four screws and move the laser unit.
4. Tighten the laser unit.
5. Print the trimming area pattern to check the image. If it is still the same, repeat step 3 to 5.

---

## 4. TROUBLESHOOTING

### 4.1 SERVICE CALL CONDITIONS

#### 4.1.1 SUMMARY

There are 2 levels of service call conditions.

Level	Definition	Reset Procedure
A	To prevent the machine from being damaged, the SC can only be reset by a service representative. The machine cannot be operated at all.	<i>Enter engine service mode (Fusing Error Clear) and press “#”.</i>
B	The SC can be reset by turning the operation switch off and on, if the SC was caused by a sensor error.	Turn the main power switch off and on.

- NOTE:** 1) If the problem concerns electrical circuit boards, first disconnect then reconnect the connectors before replacing the PCBs.  
2) If the problem concerns a motor lock, first check the mechanical load before replacing motors or sensors.

**4.1.2 SC CODE DESCRIPTIONS**

Code No.		Symptom	Possible Cause
302	B	Charge roller current leak	<ul style="list-style-type: none"> <li>• Cartridge (charge roller) defective</li> <li>• High voltage supply board defective</li> <li>• Poor cartridge connection</li> </ul>
		A charge roller current leak signal is detected.	
320	B	Polygon motor error	<ul style="list-style-type: none"> <li>• Polygon motor</li> <li>• Polygon motor cable</li> </ul>
		The polygon motor does not reach its operating speed within 10 seconds after the polygon motor on signal, or the lock signal is not detected for more than a certain time during operation.	
322	B	1st laser synchronization error	<ul style="list-style-type: none"> <li>• Laser synchronization detector board out of position</li> <li>• Laser synchronization detector board or cable defective</li> <li>• Laser synchronization mirror out of position</li> <li>• LD unit defective</li> <li>• Engine board defective</li> </ul>
		The laser synchronization detector cannot detect the laser synchronization signal for more than 5 consecutive 100 ms intervals.	
323	B	LD drive current exceeded	<ul style="list-style-type: none"> <li>• LD unit defective</li> </ul>
		The LD driver detects this error for more than 500 ms.	
326	B	2nd laser synchronization error	<ul style="list-style-type: none"> <li>• Laser synchronization detector board out of position</li> <li>• LD unit defective</li> <li>• Engine board defective</li> </ul>
		The 1 <sup>st</sup> LD1 is already on, but the laser synchronization detector cannot detect the laser synchronization signal from the 2 <sup>nd</sup> LD for more than 5 consecutive 100 ms intervals.	
391	B	Development bias leak	<ul style="list-style-type: none"> <li>• High voltage supply board defective</li> <li>• Poor cartridge connection</li> </ul>
		A development bias leak signal is detected.	
500	B	Main motor lock	<ul style="list-style-type: none"> <li>• Main motor defective</li> <li>• Too much load on the drive mechanism</li> </ul>
		A main motor lock signal is not detected for more than 700 ms after the main motor starts to rotate, or the lock signal is not detected for more than a certain time during rotation after the last signal.	
541	A	Unstable fusing temperature	<ul style="list-style-type: none"> <li>• Thermistor defective</li> <li>• Fusing lamp open</li> <li>• Fusing thermostat open</li> <li>• Power supply board defective</li> <li>• Poor connection of the fusing unit</li> </ul>
		During warm-up, the fusing temperature rises by less than 20 °C during 11 seconds.	
		The fusing temperature detected by the thermistor was 0 °C 5 seconds after the fusing relay was turned on.	

Code No.		Symptom	Possible Cause
542	A	Fusing temperature warm-up error	<ul style="list-style-type: none"> <li>• Thermistor defective</li> <li>• Fusing lamp open</li> <li>• Fusing thermostat open</li> <li>• Power supply board defective</li> <li>• Poor connection of the fusing unit</li> </ul>
		The fusing temperature does not reach more than 80 °C 17.5 seconds after the main switch is turned on.	
543	A	Fusing overheat error	<ul style="list-style-type: none"> <li>• Fusing thermistor defective</li> <li>• Power supply board defective</li> </ul>
		A fusing temperature of over 245 °C is detected for 1 second by the fusing thermistor.	
		A fusing temperature of over 235 °C is detected for 1 second after the fusing lamp has been turned off.	
545	A	Fusing lamp stays on	<ul style="list-style-type: none"> <li>• Fusing thermistor defective</li> <li>• Power supply board defective</li> <li>• Poor connection of the fusing unit</li> </ul>
		The fusing lamp stays on more than 12 seconds after the main motor has been turned off.	
546	A	Unstable fusing temperature	<ul style="list-style-type: none"> <li>• Fusing thermistor defective</li> <li>• Power supply board defective</li> <li>• Poor connection of the fusing unit</li> </ul>
		During standby, within 500 ms, the fusing temperature goes below 60 °C twice or over 60 °C three times.	
		Within 1 minute, a 60 °C increase or decrease in fusing temperature is detected during five different one-second intervals.	
547	B	Zero cross signal malfunction	<ul style="list-style-type: none"> <li>• Power supply board defective</li> <li>• Poor mains power supply condition</li> </ul>
		Zero cross signals are not detected within 5 seconds.	
610	B	Communication error - duplex unit	<ul style="list-style-type: none"> <li>• Poor connection between engine board and duplex unit</li> <li>• Engine board defective</li> <li>• Duplex control board defective</li> </ul>
		The engine board cannot communicate with the duplex unit.	
650	B	Communication error - GAVD	<ul style="list-style-type: none"> <li>• Engine board defective</li> </ul>
		<ul style="list-style-type: none"> <li>• The engine board detects an unknown device on the I<sup>2</sup>C I/F bus (internal bus on the engine control board).</li> <li>• The engine board detects an I<sup>2</sup>C I/F bus error.</li> </ul>	
651	B	Communication error - FCI	<ul style="list-style-type: none"> <li>• Engine board defective</li> </ul>
		<ul style="list-style-type: none"> <li>• The engine board detects an unknown device on the I<sup>2</sup>C I/F bus (internal bus on the engine control board).</li> <li>• The engine board detects an I<sup>2</sup>C I/F bus error.</li> </ul>	
726	B	Shift tray motor error	<ul style="list-style-type: none"> <li>• Shift motor defective</li> <li>• Shift tray: Left shift sensor or right shift sensor defective</li> </ul>
		Tray shift did not finish within a certain time after the shift motor turned on.	



## 4.2 CONTROLLER ERROR

The following table describes the controller error codes. These codes are displayed at power-on, or after the power-on self test, if an error occurs.

Please refer to section 5.3 for details of the power-on self test.

Code	Description	Required Action
640	Engine to controller communication error.	<ul style="list-style-type: none"> <li>• Check the connection between the controller and the engine board.</li> <li>• Replace the engine board if the error is frequent.</li> <li>• Replace the controller if the error is frequent.</li> </ul>
641	Engine to controller communication error (no answer).	<ul style="list-style-type: none"> <li>• Check the connection between the controller and the engine board.</li> <li>• Replace the engine board if the error is frequent.</li> </ul>
800	Video data error	<ul style="list-style-type: none"> <li>• Check the connection between the controller and the engine board.</li> <li>• Replace the engine board if the error is frequent.</li> </ul>
820	Controller CPU error	<ul style="list-style-type: none"> <li>• Replace the controller if the error is frequent.</li> </ul>
821	CPU and ASIC timer error	<ul style="list-style-type: none"> <li>• Turn off the machine and turn it back on.</li> <li>• Replace the controller if the error is frequent.</li> </ul>
822	HDD timeout error	<ul style="list-style-type: none"> <li>• Check the connection between the HDD and the controller</li> <li>• Replace the HDD if the error is frequent.</li> </ul>
823	NIB self test error	<ul style="list-style-type: none"> <li>• Turn off the machine and turn it back on.</li> <li>• Check the connection between the NIB and the controller.</li> <li>• Replace the NIB if the error is frequent.</li> </ul>
824	NVRAM error	<ul style="list-style-type: none"> <li>• Replace the NVRAM if the error is frequent.</li> </ul>
827	SDRAM error	<ul style="list-style-type: none"> <li>• Replace the controller if the error is frequent.</li> </ul>
828	Flash ROM error	<ul style="list-style-type: none"> <li>• Replace the controller if the error is frequent.</li> </ul>
829	Optional RAM error	<ul style="list-style-type: none"> <li>• Check the connection of the optional memory.</li> <li>• Replace the optional memory if the error is frequent.</li> </ul>
835	Parallel interface error	<ul style="list-style-type: none"> <li>• Replace the controller if the error is frequent.</li> </ul>
836	Font ROM error	<ul style="list-style-type: none"> <li>• Not used for this model.</li> </ul>
837	Optional font ROM error	<ul style="list-style-type: none"> <li>• Not used for this model.</li> </ul>
838	Clock generator error	<ul style="list-style-type: none"> <li>• Replace the controller if the error is frequent.</li> </ul>
850	NIB interface error	<ul style="list-style-type: none"> <li>• Replace the controller if the error is frequent.</li> </ul>
851	IEEE1394 interface error	<ul style="list-style-type: none"> <li>• Replace the controller if the error is frequent.</li> </ul>

<b>Code</b>	<b>Description</b>	<b>Required Action</b>
860	HDD start-up error	<ul style="list-style-type: none"><li>• Turn off the machine and turn it back on.</li><li>• Check the connection between the HDD and the controller.</li><li>• Replace the HDD if the error is frequent.</li></ul>
862	HDD damaged cluster error	<ul style="list-style-type: none"><li>• Replace the HDD if the error is frequent.</li></ul>
863	HDD data unable to read	
864	HDD data access error	
865	HDD access error	
900	Controller counter error	<ul style="list-style-type: none"><li>• Replace the NVRAM if the error is frequent.</li></ul>
999	Software update error	<ul style="list-style-type: none"><li>• Try downloading the controller software again.</li></ul>

## 4.3 ELECTRICAL COMPONENT DEFECTS

### 4.3.1 SENSORS

Component	CN	Condition	Symptom
Paper Exit	6-B2	Open	The Paper Jam indicator will light whenever a print is made.
		Shorted	The Paper Jam indicator lights even if there is no paper.
Paper Overflow	6-B5	Open	The paper overflow message is not displayed even when a paper overflow condition exists.
		Shorted	The paper overflow message is displayed.
Registration	16-A2	Open	The Paper Jam indicator will light whenever a print is made.
		Shorted	The Paper Jam indicator lights even if there is no paper.
1st Paper End	16-A5	Open	The Paper End indicator lights even if paper is placed in the 1st paper tray.
		Shorted	The Paper End indicator does not light even if there is no paper in the 1st paper tray.
1st Paper Height	16-A8	Open	The machine cannot determine the paper near-end condition properly.
		Shorted	
Toner End	16-A12	High	Toner near-end (toner end) is not detected.
		Low	The add toner message is displayed.

**NOTE:** The CN numbers describe the connector number on the engine board.

### 4.3.2 SWITCHES

Component	CN	Condition	Symptom
Main	272-1,3 (PSU 120V) 270-1,2 (PSU 230V)	Open	The machine does not turn on.
		Shorted	The machine does not turn off.
Front Cover Safety	9-1	Open	The Front Cover Open message is not displayed even if the front cover is opened.
		Shorted	The Front Cover Open message is displayed even if the front cover is closed.
Rear Cover Safety	9-3 5-3	Open	The Rear Cover Open message is not displayed even if the rear cover or paper exit cover is opened.
		Shorted	The Rear Cover Open message is displayed even if the rear cover or paper exit cover is closed.

**NOTE:** The CN numbers describe the connector number on the engine board (except for the main switch).

## 4.4 BLOWN FUSE CONDITIONS

Fuse	Rating		Symptom when turning on the main switch
	115 V	220 - 240 V	
<b>Power Supply Board</b>			
FU1	15 A/125 V	----	Machine does not start
FU2	6.3 A/250 V	3.15 A/250 V	Machine does not start
FU3	5 A/125 V	5 A/250V	Machine does not start
FU4	5 A/125 V	5 A/250V	Machine does not start (The LEDs turn on for a moment.)

## 4.5 LEDS

No LEDs are used for this model (except for the NIB - refer to section 6.7).



## 5. SERVICE TABLES

### 5.1 SERVICE PROGRAM MODE

#### CAUTION

Before accessing the service menu, do the following:

Confirm that there is no print data in the printer buffer (the Data In LED must not be lit or blinking).

If there is some data in the buffer, wait until all data has been printed.

#### 5.1.1 ENABLING AND DISABLING SERVICE PROGRAM MODE

##### *Entering the Service Mode*

There are two ways to enter the service mode.

**Method 1:** Turn the machine on while pressing the “On Line” key and “Escape” key together until “1. Service Menu1” appears on the display.

**NOTE:** If you switch the machine off, any jobs stored on the hard disk using the sample print and protected print features will be deleted. Check first with the user tools to see if there are any jobs stored with these features (Menu key - Sample Print, or Protected Print).

**Method 2:** Press the “Up/Down arrow” keys together for about 5 seconds, then press the “Enter” key. “1. Service Menu1” appears on the display.

**NOTE:** The machine automatically goes off line when you enter the service mode.

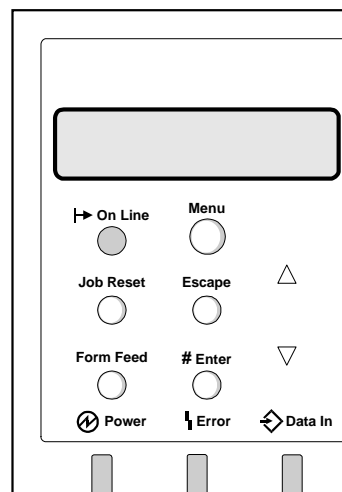

Service  
Tables

##### *Accessing the Required Program*

Use the “Up/Down arrow” keys to scroll through the menu listing.

1. Service Menu: Controller service modes
2. Engine Mainte: Engine service modes
- 3: End: Exit service mode

To select an item, press the “Enter” key. Then the sub-menu will appear. Scroll through the sub menu items using the “Up/Down arrow” keys. To go back to a higher level, press the “Escape” key.

***Inputting a Value or Setting for a Service Program***

Enter the required program mode as explained above. The setting appearing on the display is the current setting.

Select the required setting using the “Up/Down arrow” keys, then press the “Enter” key. The previous value remains if the “Enter” key is not pressed.

***Exiting Service Mode***

Select “3. End” from the service mode main menu, then press the “Enter” key.

**NOTE:** To make the settings effective, turn the main switch off and on after exiting service mode.

## 5.2 PRINTER CONTROLLER SERVICE MODE

### 5.2.1 SERVICE MODE MENU ('1. SERVICE MENU')

Service Mode	Description	Function
BitSw#1 Set	Bit switch settings	Adjusts bit switch settings. <b>Note:</b> Currently the bit switches are not being used.
Clear Setting	Initializes the system settings	Initializes settings in the "System" menu of the user mode.
Service Print	Controller summary print	Prints the service summary sheet (a summary of all the controller settings).
Disp Version	Display controller	Displays the version of the controller firmware.

### 5.2.2 BIT SWITCH PROGRAMMING



**NOTE:** Currently, the bit switches are not being used.

1. Enter the SP mode, select "Service Menu", then press [Enter] twice.

```
Service Menu
BitSW
```

2. Select #1, #2, #3, or #4 for the desired bit switch, then press [Enter].
  - [▲] [▼]: Move to the next switch.

```
BitSW
<BitSW#1>
```

3. Adjust the bit switch using the following keys.
  - [▲] [▼]: Move to the next bit.
  - [Escape]: Exit without saving changes.
  - [Enter]: Exit and save changes.

```
Sw#1  00000000
Bit0  _
```

**NOTE:** The left digit on the display is bit 7 and the right digit is bit 0.

4. Press [Enter] to save changes and exit.

Service Tables

## 5.3 PRINTER ENGINE SERVICE MODE

### 5.3.1 SERVICE MODE TABLE ('2. ENGINE MAINTENANCE')

Service Mode	Description	Function	Setting
Regist sag	Paper feed timing	Adjusts the paper feed clutch timing at registration. The paper feed clutch timing determines the amount of paper buckle at registration. (A larger setting leads to more buckling.)	-8.0 to +8.0 2 mm/step <b>0 mm</b>
Fusing Control	Fusing power control	Selects whether the fusing power control is on/off or phase control. Use "Phase" control if the room lights flicker when the fusing lamp starts.	<b>Normal</b> (US) <b>Phase</b> (Europe/Asia)
Fusing Temp	Fusing temperature adjustment	Adjusts the fusing temperature for printing. <b>Normally, do not change the setting.</b>	100 to 200 10°C/step <b>170°C</b>
Fusing T Dis	Fusing temperature display	Displays the fusing temperature.	
OHP Clutch Rt	Bypass paper feed roller rotation for transparencies	Selects the number of rotations for the bypass tray feed roller when the paper type is set to "Transparencies." This is to avoid jams when transparencies are being used.	<b>1 (1 rotation)</b> 2 (2 rotations)
Fusing Start	Initial fusing setting	Roller turn: Warms up the fusing unit for 20 s at power on or when the machine warms up from the energy saver mode. Normal: There is no 20 s warm-up period Select 'roller turn' to avoid poor fusing in a low temperature environment.	<b>Normal</b> Roller turn
Curl Control	Low temperature fusing	Lowers the fusing temperature (to 150°C) to prevent thin paper from curling. Use this mode only when a paper jam occurs during duplex rear side printing.	<b>Normal</b> Curl control
Charge Rol Bias	Charge roller voltage adjustment	Adjusts the charge roller voltage. <b>Normally, do not change the setting.</b>	1000 to 2000 10 V/step <b>1650V</b>
Mainscan mag	Main scan magnification adjustment	Adjusts the main scan magnification.	-0.5 to +0.5 0.1 %/step <b>0 %</b>
Subscan mag	Sub scan magnification adjustment	Adjusts the sub scan magnification.	-0.5 to +0.5 0.1 %/step <b>0 %</b>
Developer Bias	Development Bias Adjustment	Adjusts the development bias for printing. <b>Normally, do not change the setting.</b>	-800 to -200 10 V/step <b>-700V</b>
Toner End Count	Number of prints after toner near-end is detected	Adjusts the number of prints the machine can print after it detects toner near-end.	50 to 200 50 sheets/step <b>200 sheets</b>

Service Mode	Description	Function	Setting
Transfer curr	Transfer current correction	Adjusts the correction current applied to the transfer roller.	0: -2 $\mu$ A <b>1: 0 <math>\mu</math>A</b> 2: +2 $\mu$ A 3: +4 $\mu$ A
Test Pattern	Test pattern selection	Use this to select and print a test pattern. This machine has the following patterns. <ul style="list-style-type: none"> <li>• No pattern</li> <li>• Checkered flag</li> <li>• Cross-stitch</li> <li>• 1-dot argyle</li> <li>• 2-dot argyle</li> <li>• 2-dot trim</li> <li>• 1-dot grid</li> <li>• 2-dot grid</li> </ul> Reset this to 0 after printing the test pattern.	<b>No pattern</b>
Thermistor adj	Thermistor adjustment	Charge roller voltage and transfer current automatic adjustment. The machine automatically adjusts these parameters in response to the temperature within the machine. <b>Normally, do not change the setting.</b>	<b>On</b> Off
Toner end clear	Toner end clear (engine)	Clears the toner end counter in the engine board. <b>Note:</b> This mode is not used in this machine.	
Waste Toner Cnt	Waste toner count display	Displays the waste toner counter in the engine board.	
Effective info	Cartridge ID chip features that are used	Selects which of the cartridge ID chip functions are enabled. <ul style="list-style-type: none"> <li>• Not used: All items are not used</li> <li>• <b>All used:</b> All items are used</li> <li>• Normal Mode: Cartridge detection/type</li> <li>• Cartridge: Cartridge detection only</li> </ul>	
Cartridge lmt	Number of prints for a single cartridge	Adjusts the number of prints the machine can make after a new cartridge is detected. <b>Do not use a higher value than 30 k.</b>	15k prints 20k prints 25k prints <b>30k prints</b> 35k prints 40k prints
Waste Lim Stop	Action when toner end is detected	Determines whether the machine stops printing after the cartridge counter reaches the above limit.	<b>Yes (Stop printing)</b> No (Do not stop)

Service Mode	Description	Function	Setting
Toner end sensor	Toner near-end threshold	Threshold adjustment for the toner end sensor. <b>Normally, do not change the setting.</b> <b>Important:</b> Turn the main switch off/on after changing this setting.	200 to 1000 100 ms/step 200 ms
Cartridge info	Toner cartridge information	Displays toner cartridge information.	
A3/11x17 Count	A3/DLT double count	Specifies whether the counter is doubled for A3/11" x 17" paper. If "Yes" is selected, the total counter counts up twice when A3/11" x 17" paper is used.	Yes (double count) <b>No (single count)</b>
Memory clr	Memory clear	Resets software counters and returns modes and settings to their defaults. <ul style="list-style-type: none"> <li>• Memory all clear: Clears all data</li> <li>• Eng: Clears the printer engine settings (See Note 1 for a list of the settings erased)</li> <li>• SCS: Clears system settings (See Note 2 for a list of the settings erased)</li> <li>• PRT: Clears user mode system settings (See Note 3 for a list of the settings erased)</li> <li>• NCS: Clears the items listed in the "Host Interface" section of the Configuration page.</li> </ul>	
Free run	Free run	The machine performs a free run. Press [Enter] to start. Press [Enter] to stop. Please note that the machine will not stop immediately after the [Enter] key is pressed.	
Input check	Input check mode	Displays signals received from sensors and switches. See the "Input Check" section for details.	
Output check	Output check mode	Turns on electrical components individually for test purposes. See the "Output Check" section for details.	
Fusing err clr	SC code reset	Resets a service call condition (for fusing unit errors). After using this SP mode, turn the main switch off and on.	
Serial number	Serial number programming	Use to input the machine serial number. (This is normally done at the factory.)	
Service TEL	Service station number programming	Program the service station number. The number is printed on the meter-charge counter report when the meter-charge mode is turned on.	
HDD Init	Initializes the HDD	Initializes the hard disk. Use this only if there is a hard disk error.	
Prog Checksum	---	Designers' use only	

Service Mode	Description	Function	Setting
Test Print	Engine test pattern print	Prints the test pattern that was selected in the "Test Pattern" mode.	
Plug/Play	Plug & Play name selection	Select the plug & play name.	
Meter charge	Meter-charge mode	<p>Enable or disable meter-charge mode.  <b>Important:</b> Turn the main switch off/on after changing this setting.</p> <p><b>Meter charge mode enabled:</b></p> <ul style="list-style-type: none"> <li>• 'Replace Maintenance Kit' is <u>not</u> displayed on the operation panel when the PM counter runs out (the technician replaces the maintenance kit items)</li> <li>• The meter charge counter is shown immediately after the Menu key is pressed.</li> <li>• The technician must reset the PM counter after replacing the fusing unit.</li> </ul> <p><b>Meter charge mode disabled:</b></p> <ul style="list-style-type: none"> <li>• 'Replace Maintenance Kit' is <u>is</u> displayed on the operation panel when the PM counter runs out (the user replaces the maintenance kit items)</li> <li>• The meter charge counter is not shown when the Menu key is pressed.</li> <li>• The PM counter resets automatically after the user replaces the fusing unit.</li> </ul>	<p>Yes (Enabled)  <b>No</b> (Disabled)</p>
Service Report	Prints engine summary	Prints the engine summary sheet.	
Operation time	Total engine rotation cycle	<p>Displays the total number of engine rotation cycles made so far.  <b>Note:</b> One cycle is calculated as 3.7 s of drum rotation. However, this counter also includes idle rotations.  This counter is not reset at PM.</p>	
Total count C	Controller total counter display	<p>Displays the controller total counter. This counter is used for meter charge, and it appears when the user presses the Menu key (if meter charge mode is enabled).  It does not count up when certain items, such as service reports, are printed (see section 6.6.1. for a complete list of conditions).</p>	
Disp ROM ver	ROM version display	Displays the firmware version (system, engine, and duplex).	

Service Mode	Description	Function	Setting
PM Counter	PM counter display	Displays the PM counter. This is not a page counter. It estimates the page count using the engine rotation cycle count. It counts up one page when the engine has made the average number of rotations that is required for one page of a three-page job.	
PM Counter reset	Resets the PM counter	Resets the PM counter. <b>Important:</b> If a technician replaces the PM items, reset this counter after replacing these items.	
Diag result	Diagnostic result display	Displays the controller self-diagnostic result. See sections 5.5 and 5.6 for details.	
Assert Info	---	Designers' use only	
Usercode clr	User code clear	Clears all the user code data from the controller board memory.	
Total counter	Engine total counter display	Displays the engine total counter. It counts up for all prints, including service reports.	

**Memory Clear**

The following tables list the items that are cleared.

**Note 1:** Eng (Engine settings)

Setting Name	User or Service Mode
Sub scan registration	User/Maintenance/Registration
Main scan registration	
Image Density	
Regist sag	Service/Printer engine
Fusing control	
Fusing temp	
OHP Clutch Rt	
Fusing start	
Curl control	
Charge Rol Bias	
Main scan mag	
Subs can mag	
Developer bias	
Toner end count	
Transfer curr	
Thermistor adj	
Effective info	
Catridge lmt	
Waste Lim Stop	
Toner end sensor	
Meter charge	



**Note 2: SCS (Clears system settings)**

Setting Name	User or Service Mode
Language	User/
Paper Type	User/Paper Input/
Tray Paper Type	
Manually programmed paper size	
Tray Lock	
Energy saver timer	User/System/
A3/11x17 Count	Service/Printer engine
Service TEL	
User code counter	---

**Note 3: PRT (Clears system settings)**

Setting Name	User or Service Mode
Tray Priority	User/Paper Input
Misfeed Recovery	User/System
Print Error Report	
Auto Continue	
Memory Overflow	
Output Tray	
Job Separation	
Memory usage	

### 5.3.2 INPUT CHECK TABLE

Number	Description	Reading	
		00H	01H
1	Front cover safety switch	Closed	Opened (Pushed)
2	Main motor lock	Off	On
3	Polygon motor lock	Off	On
4	Not used		
5	Upper rear cover (duplex cover)	Closed	Opened (Pushed)
6	Duplex unit installed	Not installed	Installed
7	Fusing unit installed	Not installed	Installed
8	New fusing unit detection	Used fusing unit	New fusing unit
9-10	Not used		
11	Paper overflow sensor	Paper not detected	Paper detected
12-15	Not used		
16	Registration sensor	Paper not detected	Paper detected
17	Paper exit sensor	Paper not detected	Paper detected
18	Duplex transport sensor (optional duplex unit)	Paper not detected	Paper detected
19	Duplex entrance sensor (optional duplex unit)	Paper not detected	Paper detected
20	Duplex exit sensor (optional duplex unit)	Paper not detected	Paper detected
21	Bypass feed paper sensor	Paper detected	Paper not detected
22	Paper end sensor - standard cassette	Paper detected	Paper not detected
23	Paper size sensor - standard cassette	See table 1	
24	Paper height sensor - standard cassette	See table 3	
25	Not used		
26	Paper end sensor - optional paper tray upper cassette	Paper detected	Paper not detected
27-28	Not used		
29	Paper end sensor - optional paper tray lower cassette	Paper detected	Paper not detected
30	Paper size sensor - optional paper tray lower cassette	See table 2	
31	Paper height sensor - optional paper tray lower cassette	See table 4	
32	Upper paper transport sensor (optional paper feed unit)	Paper not detected	Paper detected
33	Lower paper transport sensor (optional paper feed unit)	Paper not detected	Paper detected
34	Paper size sensor - optional paper tray upper cassette	See table 2	
35	Not used		
36	Paper height sensor - optional paper tray upper cassette	See table 4	
37-40	Not used		
41	Paper output tray cover sensor	Closed	Opened (Interrupted)

Number	Description	Reading	
		00H	01H
42	Shift tray paper transport sensor	Paper not detected	Paper detected
43	Shift tray at right (optional 1-bin shift tray)	Off	On (Interrupted)
44	Shift tray at left (optional 1-bin shift tray)	Off	On (Interrupted)
45	Paper sensor - 1st bin (optional 4-bin mailbox)	Paper not detected	Paper detected
46	Paper overflow sensor - 1st bin (optional 4-bin mailbox)	Paper not detected	Paper detected
47	Paper sensor - 2nd bin (optional 4-bin mailbox)	Paper not detected	Paper detected
48	Paper overflow sensor - 2nd bin (optional 4-bin mailbox)	Paper not detected	Paper detected
49	Paper sensor - 3rd bin (optional 4-bin mailbox)	Paper not detected	Paper detected
50	Paper overflow sensor - 3rd bin (optional 4-bin mailbox)	Paper not detected	Paper detected
51	Paper sensor - 4th bin (optional 4-bin mailbox)	Paper not detected	Paper detected
52	Paper overflow sensor - 4th bin (optional 4-bin mailbox)	Paper not detected	Paper detected
53	Upper paper transport sensor - Mailbox (optional 4-bin mailbox)	Paper not detected	Paper detected
54	Lower paper transport sensor - Mailbox (optional 4-bin mailbox)	Paper not detected	Paper detected
55-75	Not used		

Service Tables

**Table 1: Paper Size Switch (Main Unit)**

Number	SW 1	SW 2	SW 3	Paper Size	
				US model	Europe/Asia
23	0	0	0	---	---
	0	0	1	LG SEF	A4 LEF
	0	1	0	8 1/2" x 13"	11" x 8 1/2"
	0	1	1	11" x 8 1/2"	A4 SEF
	1	0	0	* (Asterisk)	* (Asterisk)
	1	0	1	A4 LEF	8 1/2" x 11"
	1	1	0	8 1/2" x 11"	A5 LEF
	1	1	1	11" x 17"	A3

1: Pushed

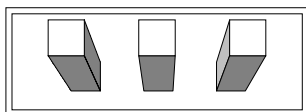

Switch No. 1      2      3

**Table 2: Paper Size Switch (optional paper tray)**

Number	SW 1	SW 2	SW 3	SW 4	Paper Size
					US/ Europe/Asia
30, 34	0	0	0	0	---
	0	0	0	1	* (Asterisk)
	0	0	1	0	---
	0	0	1	1	A4 LEF
	0	1	0	0	---
	0	1	0	1	LG SEF
	0	1	1	0	---
	0	1	1	1	A4 SEF
	1	0	0	0	---
	1	0	0	1	11" x 8 1/2"
	1	0	1	0	---
	1	0	1	1	8 1/2" x 11"
	1	1	0	0	---
	1	1	0	1	11" x 17"
1	1	1	0	---	
1	1	1	1	A3	

1: Pushed      ---: Cassette not detected

**Table 3: Paper Height Sensor (standard cassette)**

Number	SP Value	Paper Amount
24, 31	00H	More than 20%
	01H	Less than 20%

**Table 4: Paper Height Sensor (optional paper tray)**

Number	SP Value	Paper Amount
36	00H	Less than 10%
	01H	More than 90%
	02H	10 - 50%
	03H	50 - 90%

**5.3.3 OUTPUT CHECK TABLE**

<b>Number</b>	<b>Description</b>
1	Main motor (forward)
2	Paper transport clutch
3	Registration clutch
4	Not used
5	Paper feed clutch (standard cassette)
6	Bypass feed solenoid
7-10	Not used
11	Fan motor (high speed)
12	Fan motor (low speed)
13	Fusing relay
14-21	Not used
22	Polygon motor on
23	Polygon motor on and LD on
24-25	Not used
26	Upper paper feed clutch (optional paper tray unit)
27	Upper paper feed motor (optional paper tray unit)
28	Lower paper feed clutch (optional paper tray unit)
29	Lower paper feed motor (optional paper tray unit)
30	Not used
31	Paper exit motor (1-bin shift tray, 4-bin mailbox)
32	Paper exit junction gate solenoid
33	1-bin shift tray - right
34	1-bin shift tray - left
35	Mailbox turn gate solenoid 2 (optional 4-bin mailbox)
36	Mailbox turn gate solenoid 3 (optional 4-bin mailbox)
37	Mailbox turn gate solenoid 4 (optional 4-bin mailbox)
38-40	Not used
41	Duplex inverter motor (forward: optional duplex unit)
42	Duplex inverter motor (reverse: optional duplex unit)
43	Duplex transport motor (Optional duplex unit)
44	Inverter gate solenoid (Optional duplex unit)
45-50	Not used

## 5.4 FIRMWARE UPDATE PROCEDURE

### 5.4.1 CONTROLLER/NIB/ENGINE FIRMWARE UPDATE

This procedure is for upgrading the firmware of the machine.

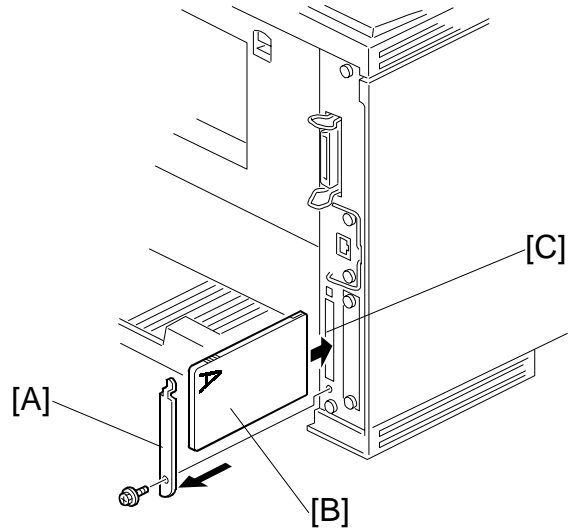
**⚠ CAUTION**

**Do not turn off the machine while downloading the firmware.**

1. Prepare an IC card that contains the required firmware.
2. Turn off the machine and remove the cover [A] (1 screw).
3. Insert the card [B] into the IC card slot [C].  
**NOTE:** When you see the machine from the back, the "A" side of the card must face the right as shown.
4. Turn on the machine. Select the software you wish to update and press [Enter].
5. Start downloading the new firmware by pressing the [Enter] key.
6. After the firmware download has finished, turn off the machine, and remove the card. Then, replace the cover [A].
7. Turn on the machine, and print the service summary report to confirm that the new firmware version has been installed.

## 5.4.2 ERROR RECOVERY

### **Controller**

If an error occurs during updating the controller firmware, use the following procedure. This procedure will force the controller to boot from the IC card.

1. Prepare an IC card with the required controller firmware version.
2. Turn off the machine and remove the controller.
3. Change the DIP switch 2 - No. 1 setting to "ON".

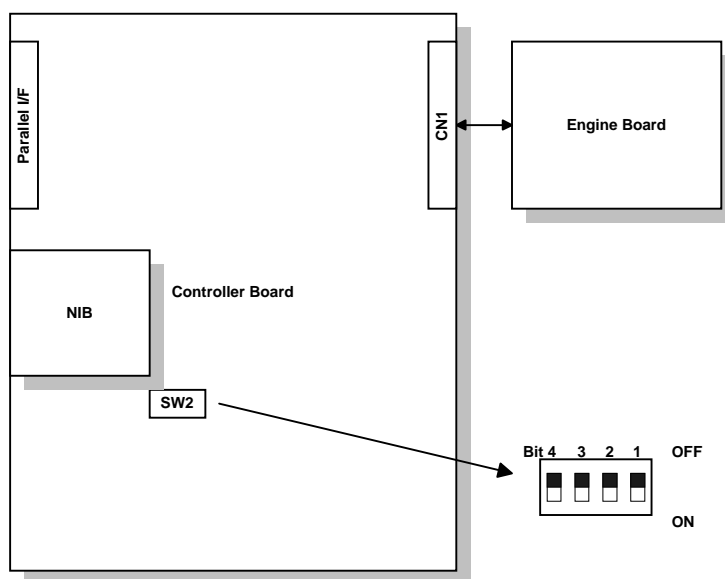

G056T500.WMF

4. Put back the controller and insert the card into the IC card slot on the controller.  
**NOTE:** When you see the machine from the back, the "A" side of the card must face the right.
5. Turn on the machine. The machine automatically starts to download the software.
6. When downloading is finished, "Update done" is displayed.
7. Turn off the machine, remove the card, and reset the DIP switch 2 - No.1 setting to "OFF". Then, put back the controller.  
**NOTE:** The default settings of the DIP switches are all 'OFF'.
8. Turn on the machine, and print the service summary report.

### **NIB/Engine Board**

If a download attempt failed, try downloading the new firmware again using the procedure described in section 5.4.1.

## 5.5 POWER-ON SELF TEST

This self diagnostic test requires a loop-back connector (P/N: G0219350).

1. Turn off the machine and attach the loop-back connector to the parallel interface.
2. Turn on the machine while pressing the “On Line” key and “# Enter” key together.
3. The machine prints the diagnostic report automatically.
  - Refer to section 5.3.1 for how to check the error codes (Engine service mode – Diag result)
  - Refer to section 4.2 for details about the error codes.

## 5.6 OTHER TESTS

The controller tests the following devices at power-on. If an error is detected, an error code is stored in the controller board.

- CPU, ASIC and clock
  - Flash ROM
  - Resident and optional SDRAM
  - Parallel interface
  - NIB
  - IEEE1394 interface (if installed)
  - NVRAM
  - Optional HDD (if installed)
- 
- Refer to section 5.3.1 for how to check the error codes (Engine service mode - Diag result)
  - Refer to section 4.2 for details about the error codes.



## 5.7 USER PROGRAM MODE

Press the “Menu” button and use the “Up/Down arrow” keys to scroll through the menu listing.

To go back to a higher level, press the “Escape” key.

After changing the settings, press the “On Line” key.

The user menu list can be printed using “Menu List” in the “List/Test Print” user mode.

### User Mode Tree

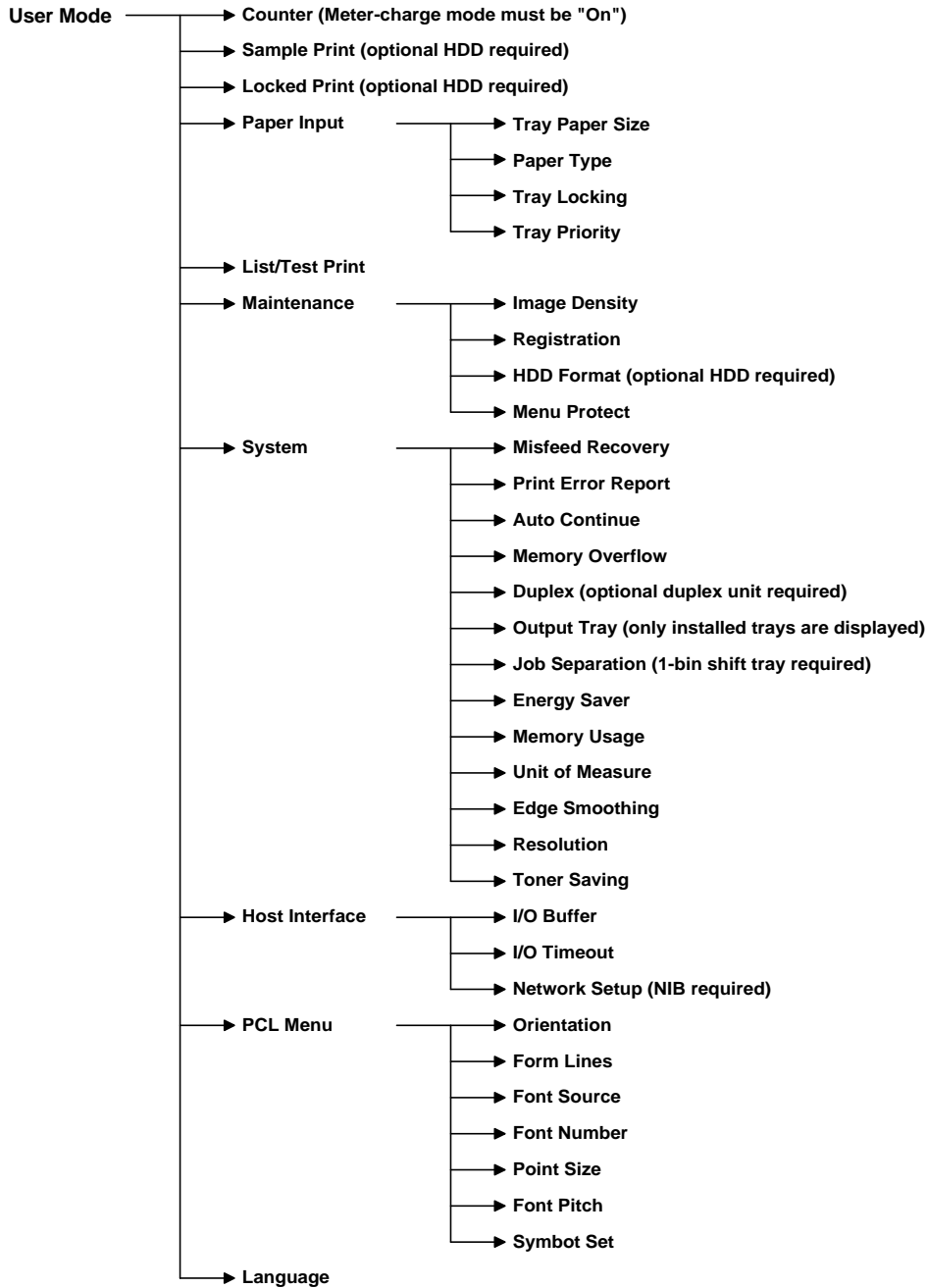

Service Tables

## 5.8 DIP SWITCHES

### ***Controller Board***

DIP switch 2 (Bit 1) on the controller is used for error recovery after a firmware updating procedure failed.

**NOTE:** The default settings of the DIP switches are all 'OFF'.

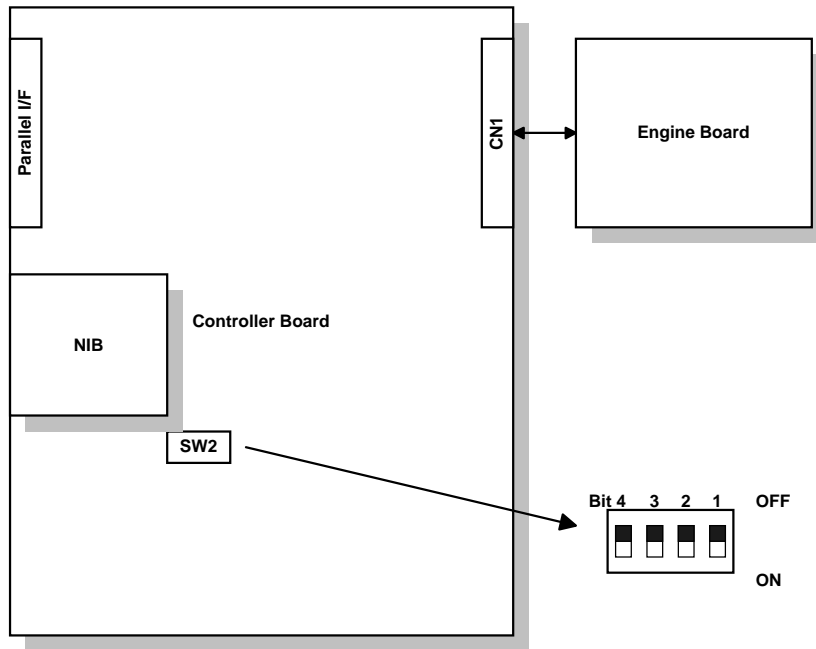

G056T500.WMF

### ***Engine Board***

DIP switch 1 on the engine board is for factory use only. Do not change the setting.

## 6. DETAILED SECTION DESCRIPTIONS

### 6.1 OVERVIEW

#### 6.1.1 MECHANICAL COMPONENT LAYOUT

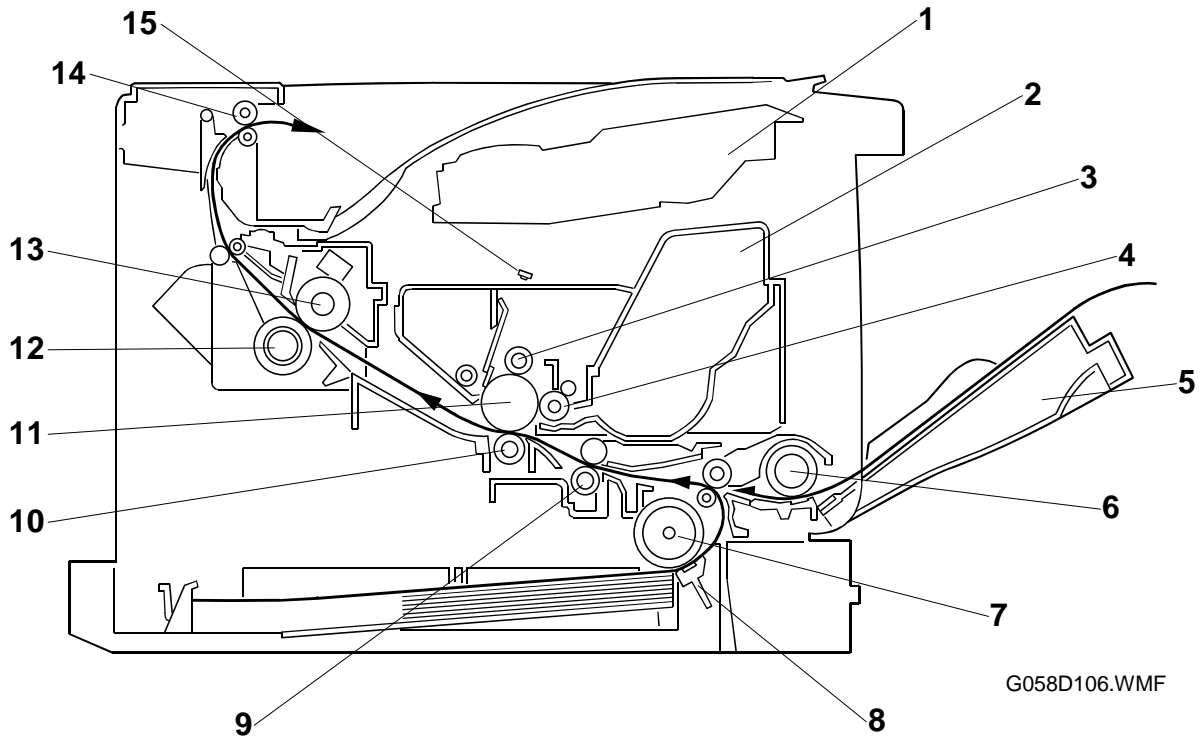

- |                         |                        |
|-------------------------|------------------------|
| 1. Laser unit           | 9. Registration roller |
| 2. Cartridge (AIO-type) | 10. Transfer roller    |
| 3. Charge roller        | 11. Drum               |
| 4. Development roller   | 12. Pressure roller    |
| 5. By-pass feed tray    | 13. Hot roller         |
| 6. By-pass feed roller  | 14. Paper exit roller  |
| 7. Paper feed roller    | 15. Quenching lamp     |
| 8. Friction pad         |                        |

Detailed  
Descriptions

### 6.1.2 PAPER PATH

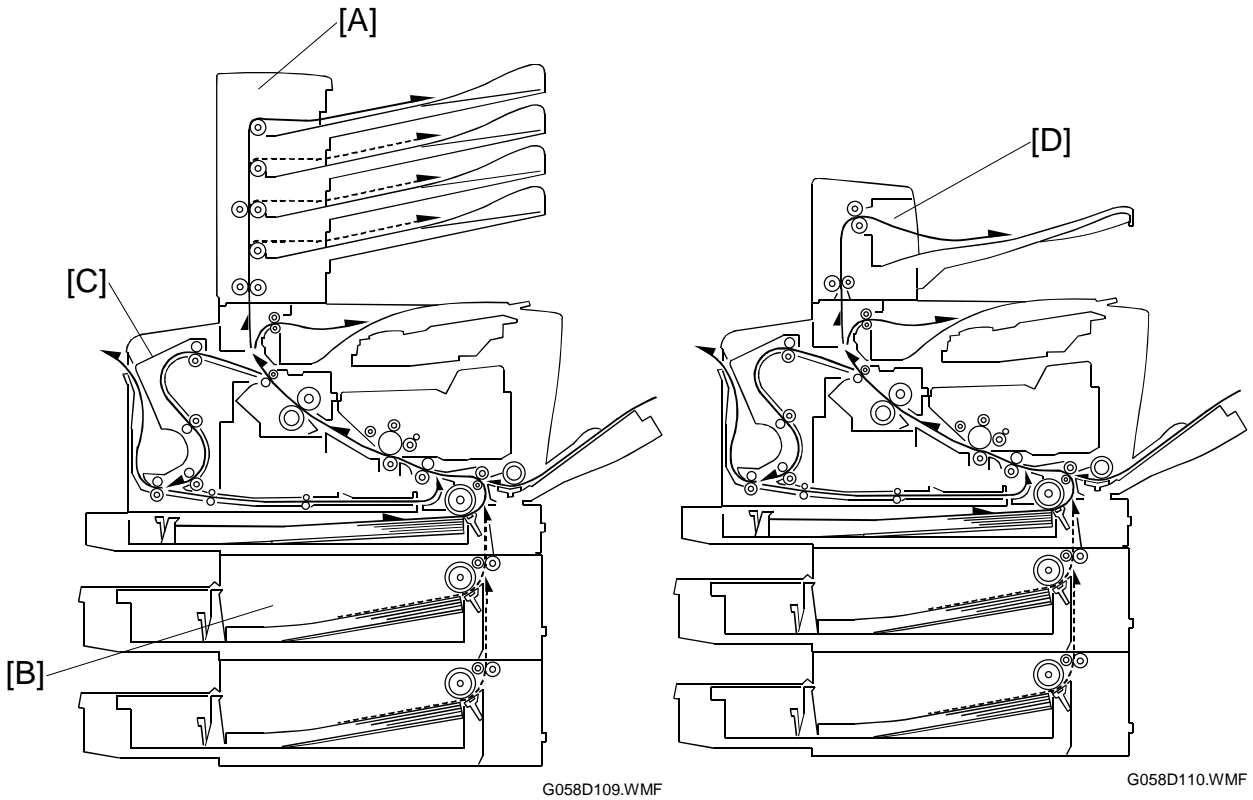

- [A]: Optional four-bin mailbox
- [B]: Optional paper tray unit  
(the top tray can be an envelope feeder)
- [C]: Optional duplex unit
- [D]: Optional one-bin shift tray unit

## 6.2 BOARD STRUCTURE

### 6.2.1 OVERVIEW

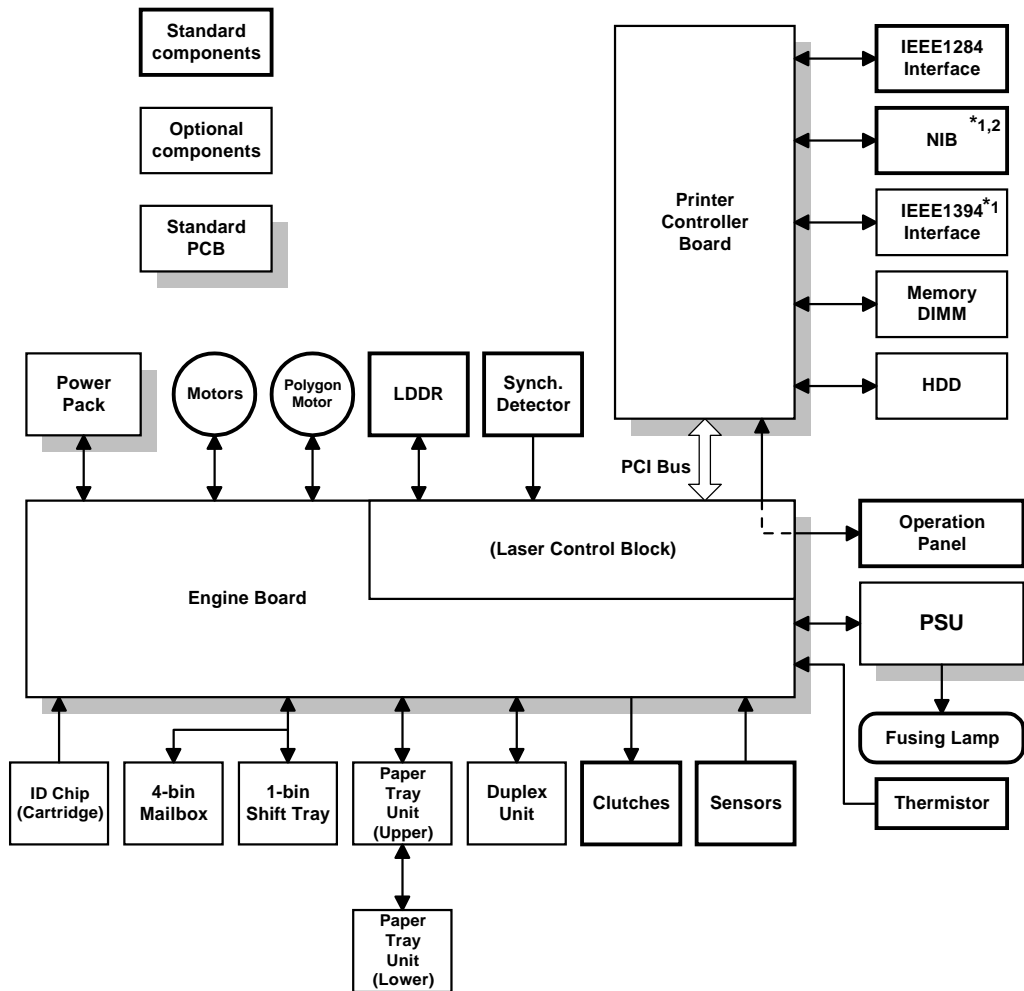

G058V501.WMF

Detailed Descriptions

The engine board controls all the mechanical components. The NIB, memory DIMM, and the HDD can be installed on the controller board.

The printer controller board connects to the engine board through a PCI bus.

The NIB (network interface board) or IEEE1394 board can be installed on the G056 model as options.

**NOTE:** 1) The NIB and the IEEE1394 board cannot be installed at the same time.  
2) The NIB is a standard component for the G058 but not the G056.

## 6.2.2 DESCRIPTIONS

### 1. Engine Board

The engine board controls the following functions:

- Engine sequence
- Machine and printer engine operation
- Timing for peripherals
- High voltage supply, laser, and fusing
- Sensors, motors, and solenoids

### 2. Printer Controller Board

The printer controller board handles the following functions:

- Printer-to-host interface
- Operation panel interface
- Interfacing and control of the NIB (or IEEE1394) and other options (HDD and DRAM DIMM)

### 3. LD Drive Board

This is the laser diode drive circuit board.

### 4. Network Interface Board (NIB )

The network interface board allows the printer to be used on a network.

### 5. IEEE1394 Interface (Option)

This allows computers to connect to this printer using an IEEE1394 interface.

### 6. HDD Unit (Option)

The HDD unit stores the data for the following.

- Additional soft fonts
- Collation
- Protected print
- Sample print
- Downloading forms for form overlay

### 7. Memory DIMM (Option: 64MB DRAM)

This is for additional printer processing memory, collation, and for soft fonts.

### 8. Control Panel Board

Controls the display panel, the LED, and the keypad.

### 9. IEEE1284 Interface

This is a parallel printer port.

### 6.2.3 CONTROLLER BOARD

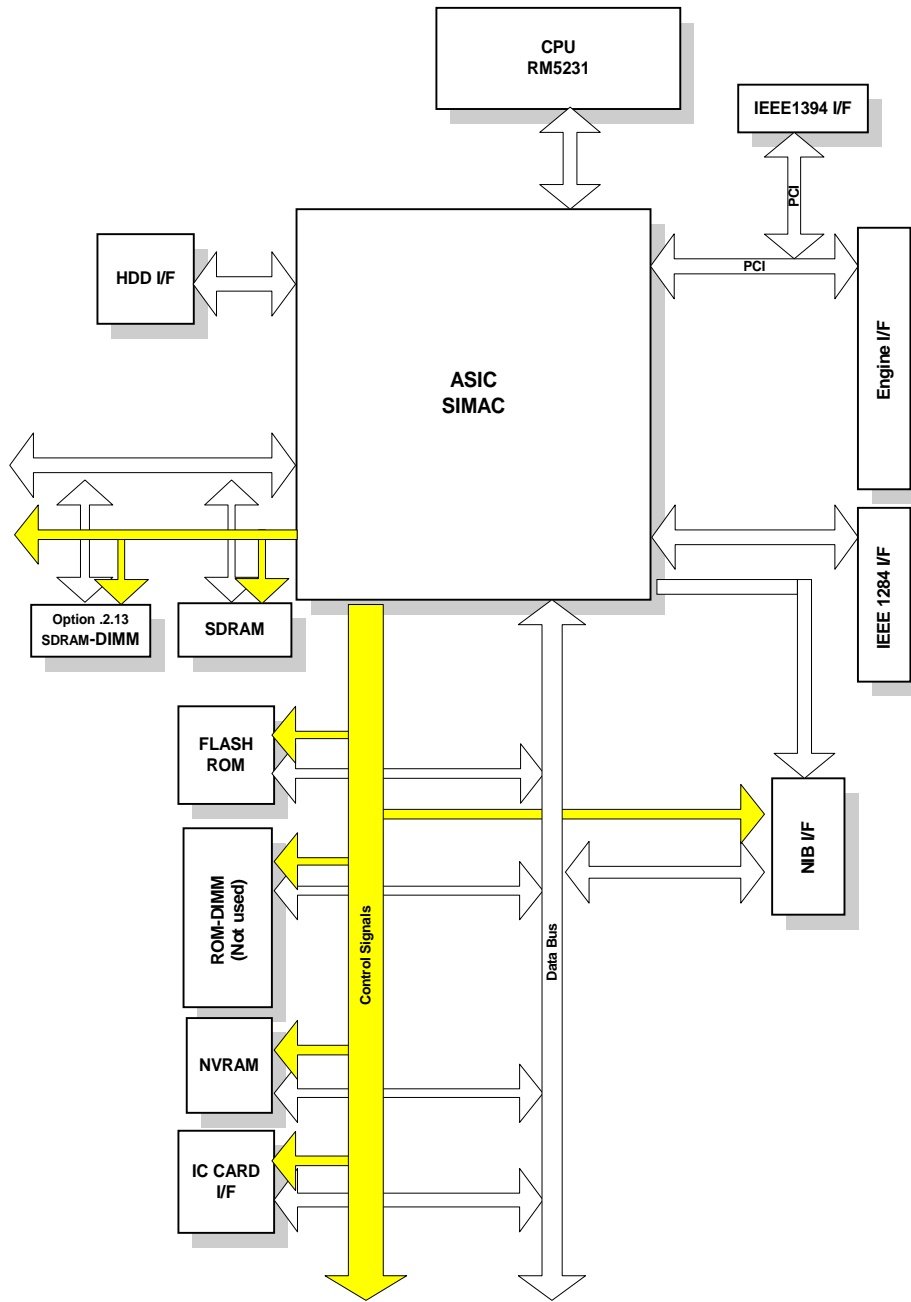

G056D507.WMF

Detailed Descriptions

- SIMAC:** The SIMAC ASIC is a multi-purpose peripheral controller. It controls all the functions of the printer controller board.
- CPU:** 32-bit CPU (RM5231-200)
- SDRAM:** 32MB SDRAM
- Flash ROM:** 8MB Flash ROM
- NVRAM:** Stores the controller settings

## 6.3 PRINTING PROCESS

### 6.3.1 OVERVIEW

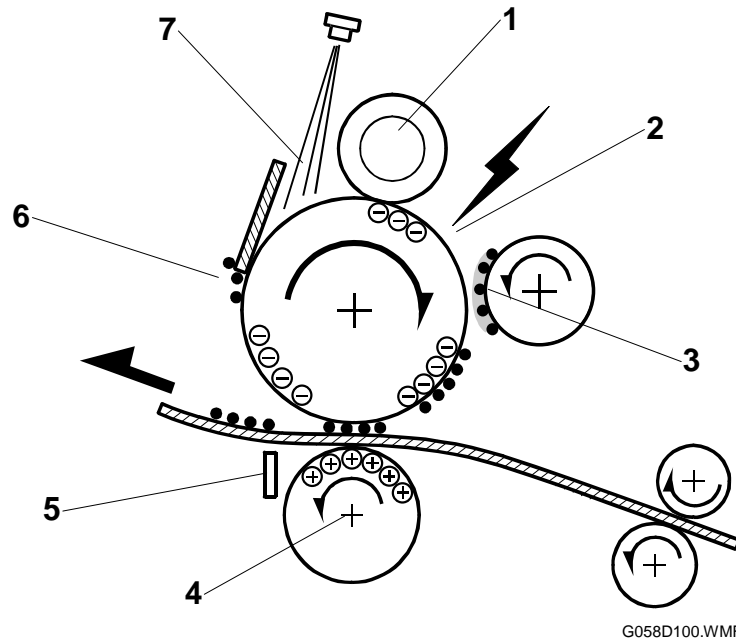

- 1) Drum charge: The charge roller gives the drum a negative charge.
- 2) Laser exposure: A laser beam transfers the print data to the drum.
- 3) Development: The development roller carries toner to the latent image on the drum surface.
- 4) Image transfer: The transfer roller pulls the toner from the drum onto the paper.
- 5) Separation: The separation plate helps to separate the paper from the drum.
- 6) Cleaning: The cleaning blade removes any toner remaining on the drum surface after the image transfers to the paper.
- 7) Quenching: The light from the quenching lamp neutralizes the charge remaining on the drum.



### 6.3.2 LASER EXPOSURE

**Overview**

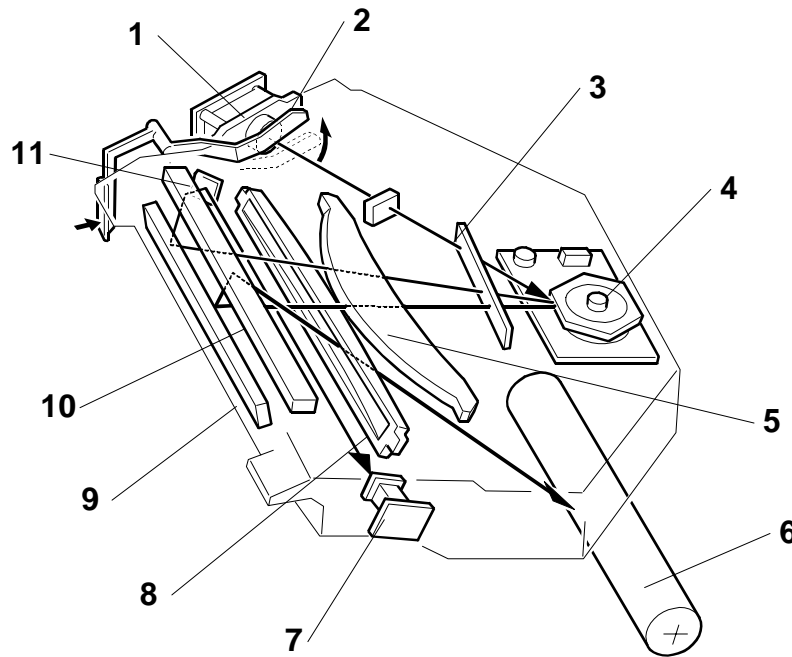

G058D201.WMF

- |                   |                             |
|-------------------|-----------------------------|
| 1. LD unit        | 7. Synchronization detector |
| 2. Laser shutter  | 8. Toroidal lens            |
| 3. Shield glass   | 9. 1st mirror               |
| 4. Polygon mirror | 10. 2nd mirror              |
| 5. F-theta lens   | 11. Detector mirror         |
| 6. Drum           |                             |

- Synchronization Detector: The beam emitted from the LD unit is reflected by the 1st mirror, 2nd mirror, and the detector mirror to the synchronizing detector.
- Two-beam Laser Writing: The LD unit writes two lines at once.
- LD Safety Shutter: When the front cover is opened, the shutter closes to block the laser beam path.
- After the LD unit has been replaced, its position must be adjusted (see Replacement and Adjustment).
- The thermistor next to the laser unit (not shown) checks the temperature inside the machine. The machine automatically adjusts the charge roller and transfer voltages in response to this temperature.

Detailed Descriptions

**Automatic Power Control (APC)**

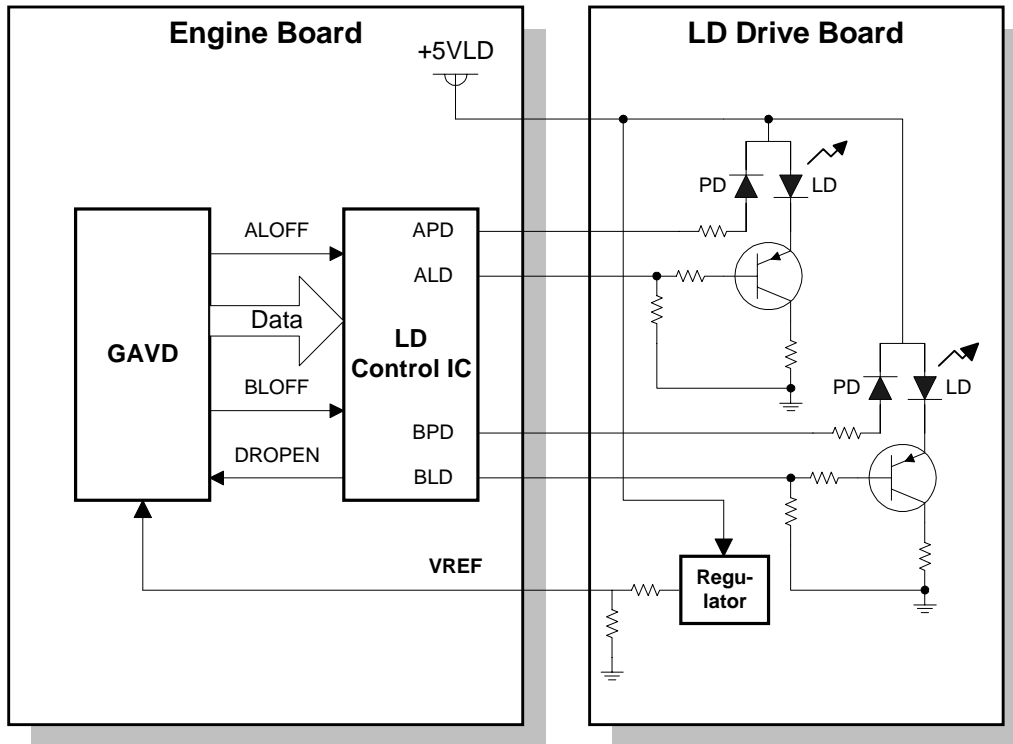

G056D503.WMF

- The LD control IC on the engine board controls this.
- The laser diode power is adjusted on the production line. Do not touch the variable resistors on the LD unit in the field.

**LD Safety Mechanisms**

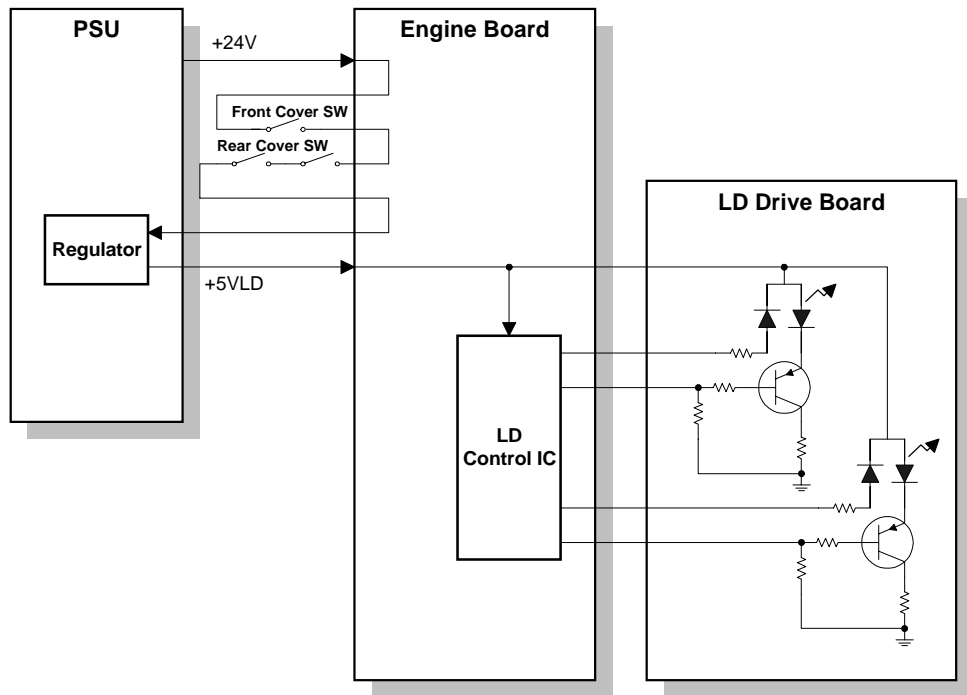

G056D504.WMF

**Laser Safety Switch**

To ensure technician and user safety and to prevent the laser from inadvertently switching on during servicing, there are safety switches on the front and rear covers.

When either of the covers are opened, the +5VLD power to the laser diodes is interrupted.

Detailed Descriptions

**Laser Shutter**

The laser shutter [A] is a back-up safety measure in case the switches are defective and the +5VLD power reaches the laser diodes.

The laser shutter cuts the laser beam when the front cover is opened.

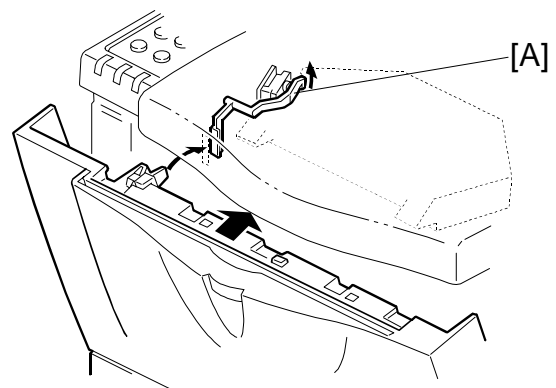

G058D202.WMF

### 6.3.3 CARTRIDGE OVERVIEW

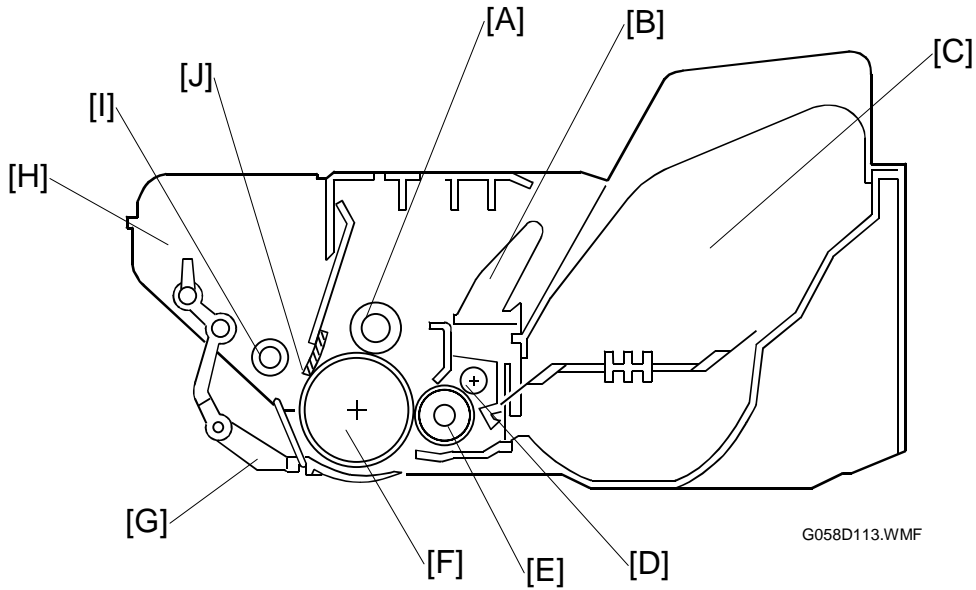

- |                         |                              |
|-------------------------|------------------------------|
| [A]: Charge roller      | [F]: Drum                    |
| [B]: Developer tank     | [G]: Drum shutter            |
| [C]: Toner tank         | [H]: Waste toner tank        |
| [D]: Reverse roller     | [I]: Toner collection roller |
| [E]: Development roller | [J]: Cleaning blade          |

- This type of cartridge is known as an “All-in One” cartridge.

### 6.3.4 DRUM CHARGE

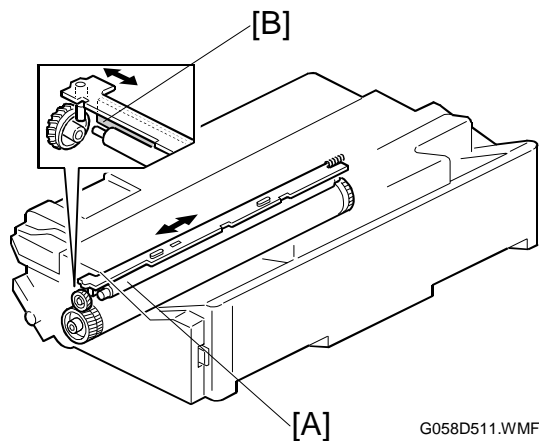

- |                    |
|--------------------|
| [A]: Charge roller |
| [B]: Cleaning pad  |

- The charge roller gives the drum surface a negative charge of about -900 V.
- The cleaning pad [A] contacts the charge roller to clean the surface.

### 6.3.5 DEVELOPMENT

#### Overview

- [A]: Toner tank
- [B]: Agitator
- [C]: Pre-doctor blade
- [D]: Development roller
- [E]: Drum
- [F]: Doctor blade
- [G]: Reverse roller
- [H]: Developer tank

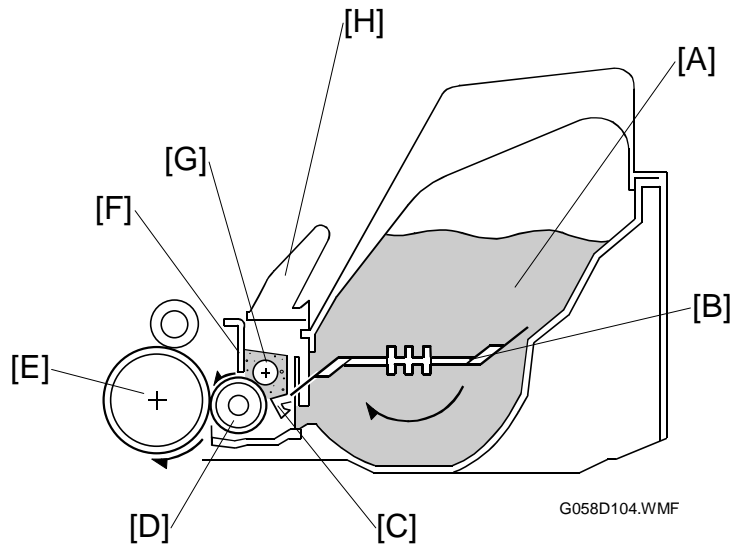

#### Toner Supply

- The agitator [B] stirs toner and carries it to the development roller.

#### Development Unit

- This machine uses a single-roller development system.
- The high voltage supply applies -700V to the development roller.
- When the developer seal is removed, developer drops and the magnetic reverse roller [G] stirs and mixes the developer.
- This machine does not use a TD sensor or ID sensor to control toner density.
- The toner density is controlled by the pre-doctor blade [C] and the doctor blade [F].

**Toner Density Control**

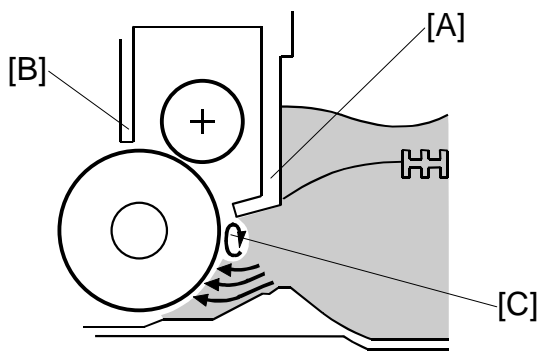

G058D120.WMF

More toner is fed when the toner coating on the development roller is thin

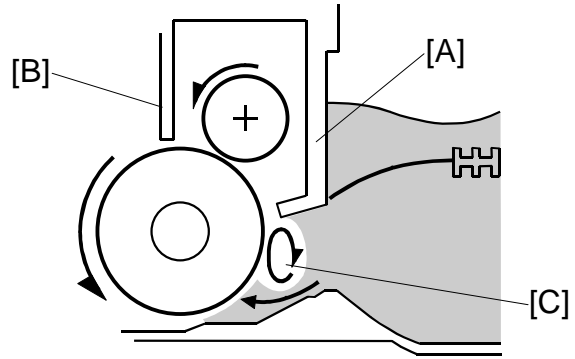

G058D121.WMF

Less toner is fed when the toner coating on the development roller is thick

- [A]: Pre-doctor blade
- [B]: Doctor blade
- [C]: Circulation of developer

A mixture of toner and developer circulates at the pre-doctor blade [A].

- When the amount of toner on the development roller decreases, the circulation [C] decreases to allow more toner to reach the development roller.
- When the amount of toner on the development roller increases, the circulation [C] increases to allow only a little toner to reach the development roller.

**Development Bias**

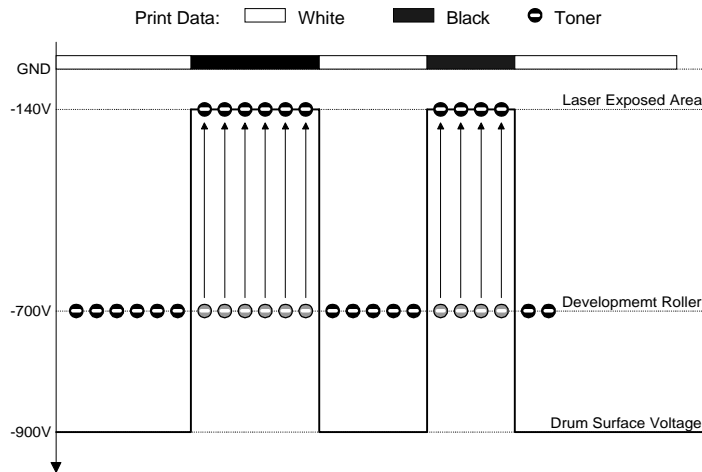

G058D510.WMF

- Toner transfers from the development roller to the areas on the drum that were exposed to the laser.

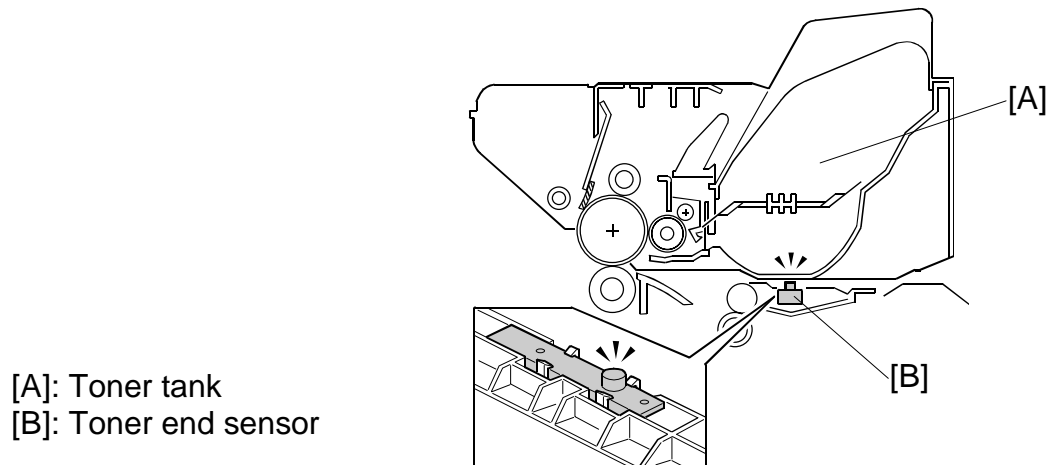
**Toner End Detection**

G058D115.WMF

- The toner end sensor detects toner near-end by the voltage output.

**Toner near-end:**

When the CPU detects that the output from the toner density sensor is below a certain level, the machine warns the user by displaying “Low on Toner” on the operation panel.

**Toner end:**

After toner near-end is detected, the machine can print 200 more pages, then it disables printing. At this time, “Replace Toner Cartridge” is displayed. The 200-page limit can be changed with engine service mode (“Toner End Count”). The machine also displays “Replace Toner Cartridge” when the output from the toner density sensor is below a certain level.

- To avoid waste toner tank overflow, the machine can also stop printing if the total number of prints per cartridge exceeds a certain limit (default setting: 30k). This number can be adjusted with “Waste Lim Count” in the engine service mode.

### 6.3.6 IMAGE TRANSFER AND PAPER SEPARATION

#### Overview

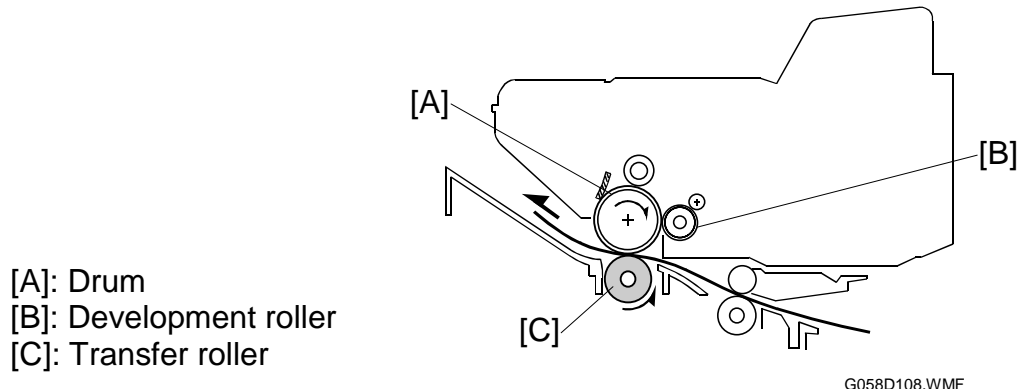

- This machine uses a transfer roller [C] to pull the toner from the drum onto the paper.
- The high voltage supply applies a positive current (+18 $\mu$ A) to the transfer roller. The current applied to the transfer roller can be adjusted with the printer engine SP mode “Transfer set.”

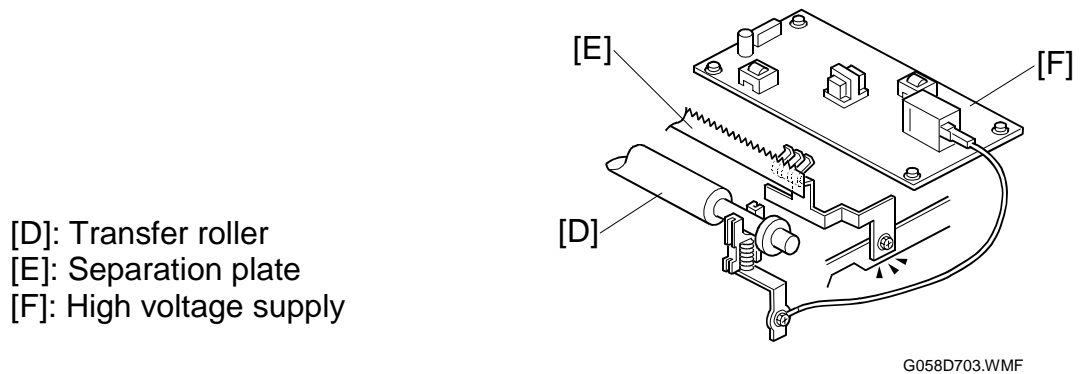

- The separation plate helps to separate paper from the drum.

#### Transfer Roller Cleaning

After a paper jam or when the wrong paper size was set, toner may transfer to the back side of printouts. To prevent this, the machine automatically cleans the transfer roller before the next print run.

During transfer roller cleaning, the high voltage supply applies a negative current (-3 $\mu$ A) to the transfer roller.

The machine cleans the transfer roller under the following conditions.

- At power on
- During fusing unit warm-up
- Immediately after a jam has been cleared
- Any time the front cover is opened and closed
- After a job which is 10 pages or larger



### 6.3.7 CLEANING

- [A]: Cleaning blade
- [B]: Drum
- [C]: Toner collection roller
- [D]: Waste toner tank

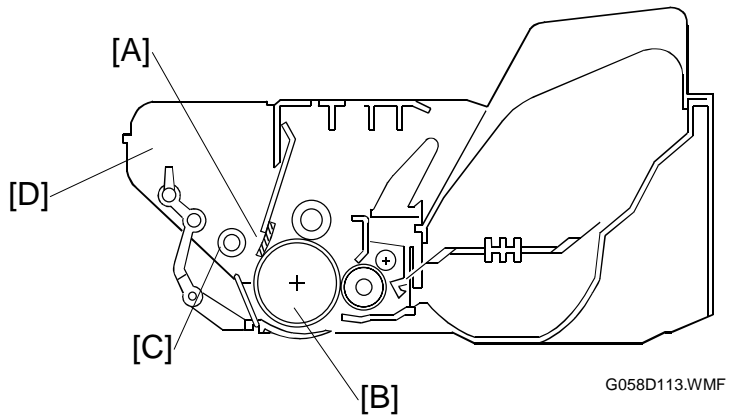

- The cleaning blade [A] removes any toner remaining on the drum.
- The toner collection roller [C] brings the toner into the waste toner tank.
- There is no waste toner overflow detection. See "Toner End Detection" for details on avoiding waste tank overflow.

### 6.3.8 QUENCHING

- [A]: Quenching lamp
- [B]: Drum

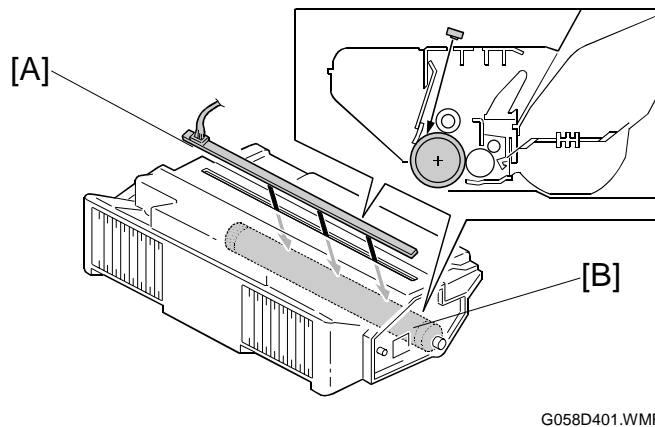

Detailed Descriptions

- Light from the quenching lamp (LED) reaches the drum through the slit at the top of the cartridge.

### 6.3.9 ID CHIP

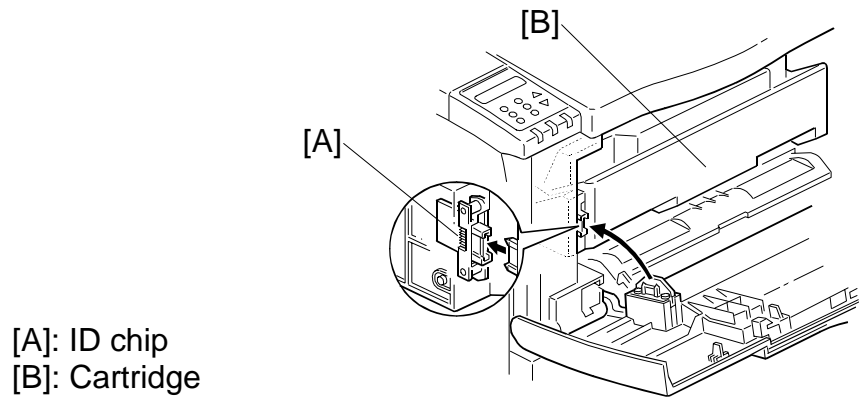

G058D530.WMF

- An ID chip is installed in the cartridge which contains cartridge information.

## 6.4 PAPER FEED

### 6.4.1 OVERVIEW

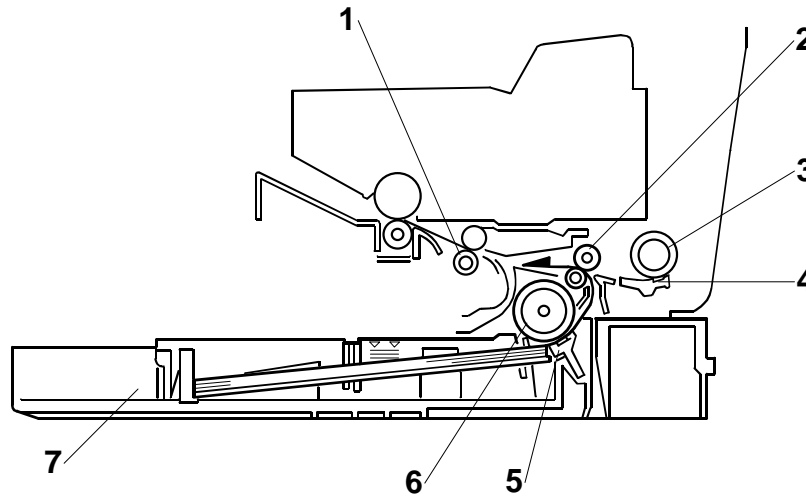

G058V112.WMF

- |                         |                 |
|-------------------------|-----------------|
| 1. Registration roller  | 5. Friction pad |
| 2. Relay roller         | 6. Feed roller  |
| 3. By-pass feed roller  | 7. Paper tray   |
| 4. By-pass friction pad |                 |

#### **Paper Tray**

Paper Feed System:	Feed roller and friction pad
Paper Lift Mechanism:	Tray arm and spring
Paper Detection:	Paper end sensor and paper near-end sensor
Paper Size Detection:	Paper size switch
Tray Capacity:	250 sheets
Tray Extension:	Available

#### **By-pass Tray**

Paper Feed System:	Feed roller and friction pad
Paper Lift Mechanism:	Cams and springs
Paper Detection:	By-pass tray paper sensor
Paper Size Detection:	None
Tray Capacity:	100 sheets

Detailed Descriptions

## 6.4.2 PAPER TRAY

### Tray Extension

The tray can be extended manually to hold paper longer than A4/Letter size. To use longer paper, release the catches [A] at both sides, then extend the tray and re-lock the catches.

The paper sizes in the following table can be used.

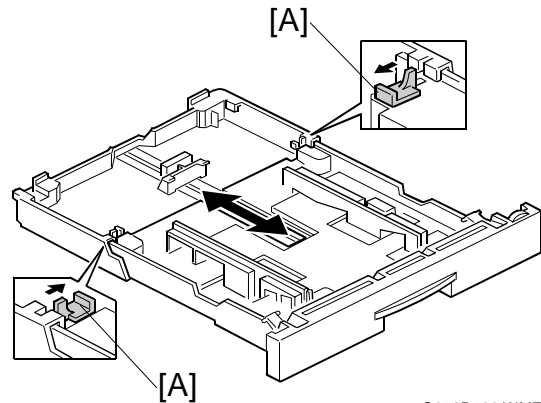

G056D500.WMF

Tray Mode	Possible Paper Sizes
Short (default)	A5 (LEF), B5 (LEF), A4 (LEF/SEF), 10.5"x7.25" (LEF), LT (LEF/SEF)
Long	B4 (SEF), A3 (SEF), 8.5"x13" (SEF), 8"x13" (SEF), 8.25"x13" (SEF), LG (SEF), DLT (SEF)

### Paper Lift

When the tray [A] is put in the machine, the bottom plate [B] is lifted as follows.

- The slopes on the guide blocks [C] on the machine lift the tray arms [D] up.
- The springs [E] between the tray arms and bottom plates lift the plate.
- The springs [E] keep the stack of the paper at the correct height.
- There is no height sensor.

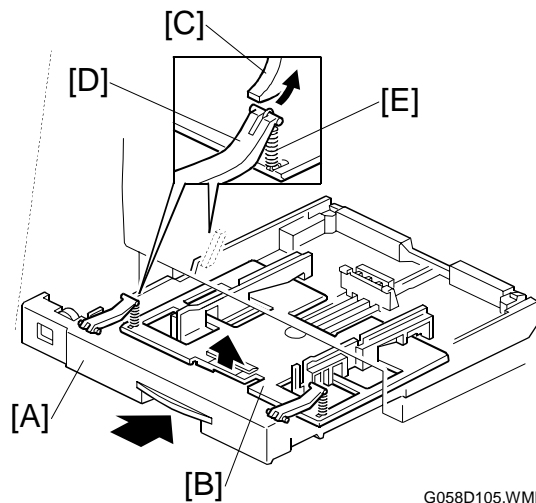

G058D105.WMF

**Paper Feed and Registration**

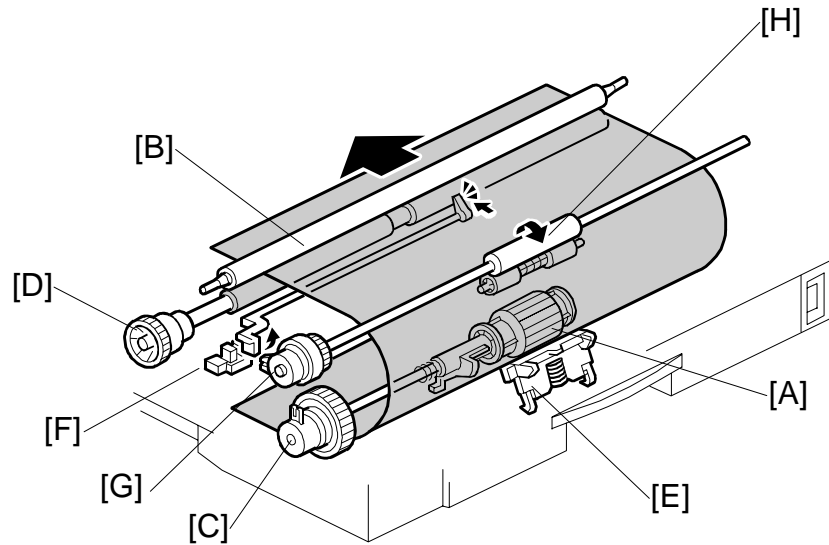

- [A]: Feed roller
- [B]: Registration roller
- [C]: Paper feed clutch
- [D]: Registration clutch
- [E]: Friction pad
- [F]: Registration sensor
- [G]: Relay clutch
- [H]: Relay roller

G058D102.WMF

- The friction pad pressure cannot be adjusted.
- The machine makes a paper buckle at the registration roller to correct paper skew.  
The paper buckle can be adjusted by Engine Service Mode; Regist Sag.

Detailed Descriptions

**Paper Size Detection**

Size		SW	1	2	3
		NA			
DLT	A3		○	○	○
LG	A4 LEF		○	●	●
LT LEF	A4 SEF		○	○	●
LT SEF	A5 LEF		●	○	○
8.5"x13"	LT LEF		●	○	●
A4 LEF	LT SEF		○	●	○
*	*		●	●	○

●: On (Not pushed)  
○: Off (Pushed)

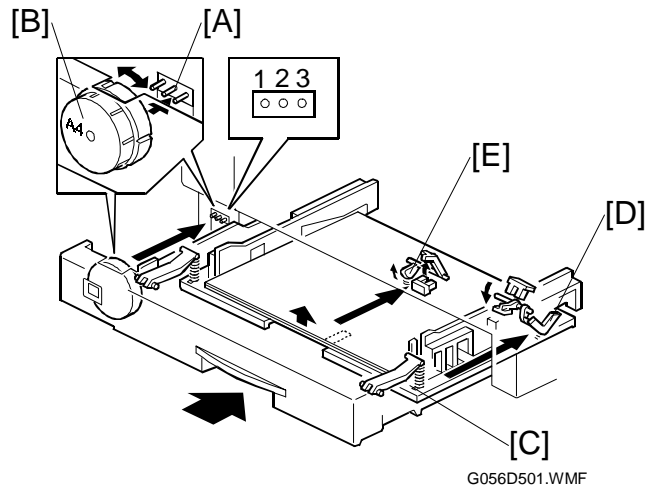

G056D501.WMF

- [A]: Paper size microswitches
- [B]: Paper size dial
- [C]: Bottom plate
- [D]: Paper near-end sensor
- [E]: Paper end sensor

- The machine disables paper feed from a tray if the paper size cannot be detected (if the paper size actuator is broken or no tray is installed)
- When the paper size dial is at the “\*” mark, the paper tray can be set up to accommodate one of a wider range of paper sizes by using a User Tool at the machine’s operation panel (Paper Input menu – Tray Paper Size).

**Paper End/Paper Near-end Detection**

**Paper Near-end Detection**

When about 50 sheets are left on the tray, the bottom plate [C] pushes up the feeler of the paper near-end sensor [D]. The signal from the sensor is only used by the host computer; there is no indication on the operation panel.

**Paper End Detection**

When the paper tray runs out of paper, the feeler of paper end sensor [E] drops into the cutout in the bottom plate and the paper end sensor is activated.

### 6.4.3 BY-PASS TRAY

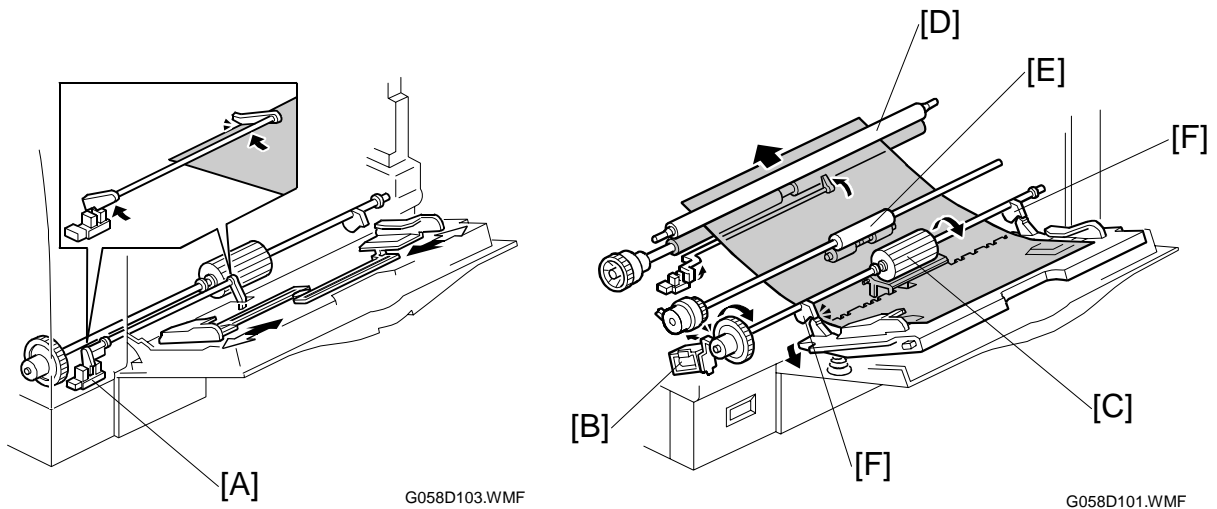

- The by-pass paper sensor [A] detects when paper is placed on the tray.
- The CPU energizes the by-pass feed solenoid [B], then the by-pass feed roller [C] starts to feed paper to the registration roller [D] through the relay roller [E].
- The by-pass feed roller shaft has two cams [F]. These cams release the bottom plate to press the stack of paper against the feed roller.
- There is no width sensor.

## 6.5 IMAGE FUSING AND PAPER EXIT

### 6.5.1 OVERVIEW

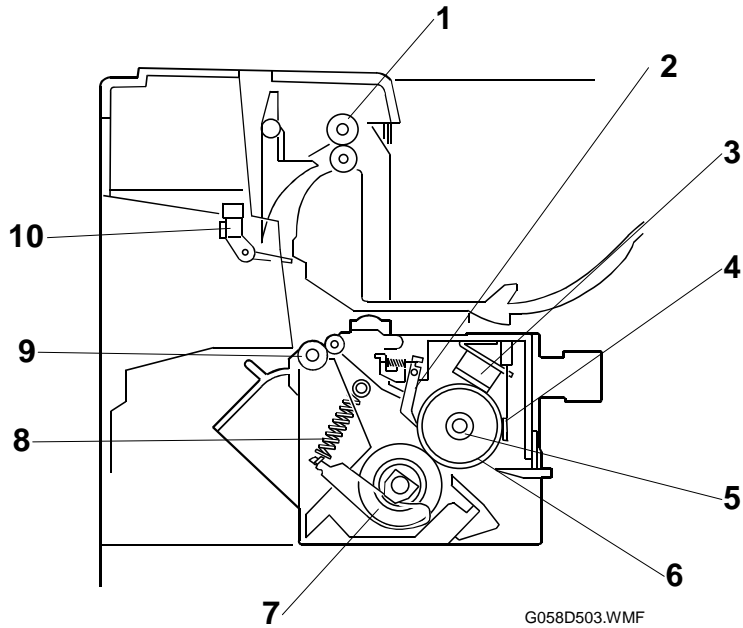

- |                         |                           |
|-------------------------|---------------------------|
| 1. Paper exit roller    | 6. Hot roller             |
| 2. Hot roller strippers | 7. Fusing pressure roller |
| 3. Thermostat           | 8. Pressure spring        |
| 4. Thermistor           | 9. Fusing exit roller     |
| 5. Fusing lamp          | 10. Paper exit sensor     |

### 6.5.2 FUSING DRIVE

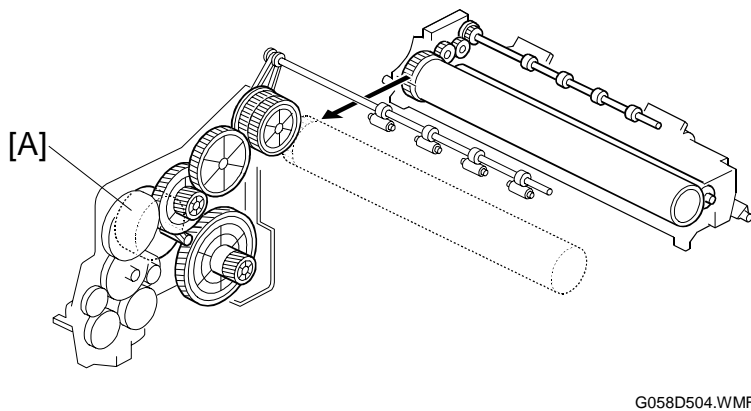

- The main motor [A] drives the fusing unit through a gear train.



### 6.5.3 FUSING ENTRANCE GUIDE SHIFT

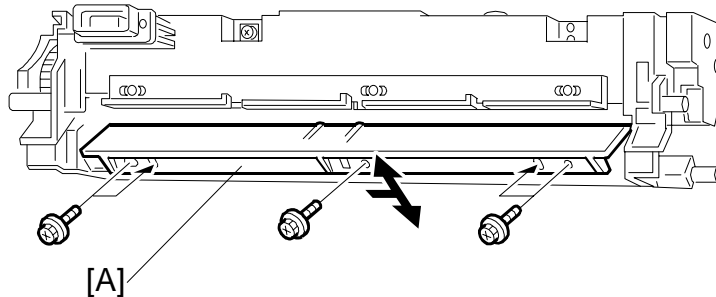

G058R509.WMF

- The entrance guide [A] is adjustable for paper thickness to prevent creasing. The outer-most screw holes on each side are the factory positions.
- If creasing occurs frequently in the fusing unit, change the entrance guide position by securing it with the other holes. This allows paper to have more direct access to the gap between the hot roller and the pressure roller.

### 6.5.4 PRESSURE ROLLER

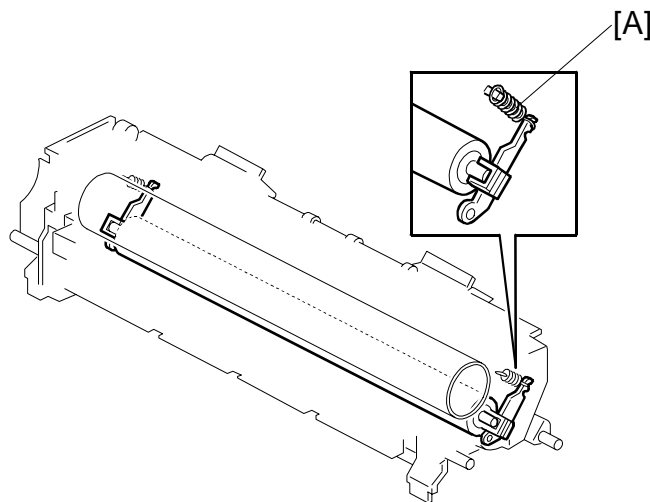

G058D505.WMF

- To change the applied pressure, adjust the position of the pressure springs. The factory setting for the spring position is at the top (minimum pressure).

## 6.5.5 NEW FUSING UNIT DETECTION

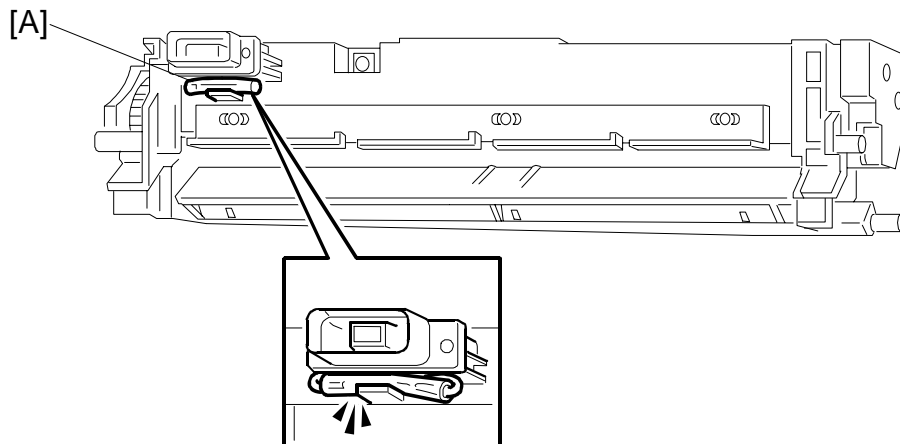

G058R512.WMF

There are two types of fusing unit: Service part, and maintenance kit part. Only the fusing unit in the maintenance kit has this detection mechanism.

In the maintenance kit fusing unit, the looped wire on the fusing unit connector contains a fuse [A]. When power is switched on after installing a new fusing unit, the engine board detects the fusing unit through the looped wire as usual. However, the fuse opens very shortly afterwards.

What happens next depends on the setting of Engine Service Mode - Meter Service Charge:

- If Meter Charge Mode is enabled-

- After the technician replaces the fusing unit, the maintenance counter must be reset with an SP mode (Engine Service Mode - PM Counter Reset).

- If Meter Charge Mode is disabled (default setting) -

- After the fusing unit has been replaced, the CPU detects the new unit and automatically removes the "Replace Maintenance Kit" message. Then, the maintenance counter resets automatically.

### 6.5.6 FUSING TEMPERATURE CONTROL

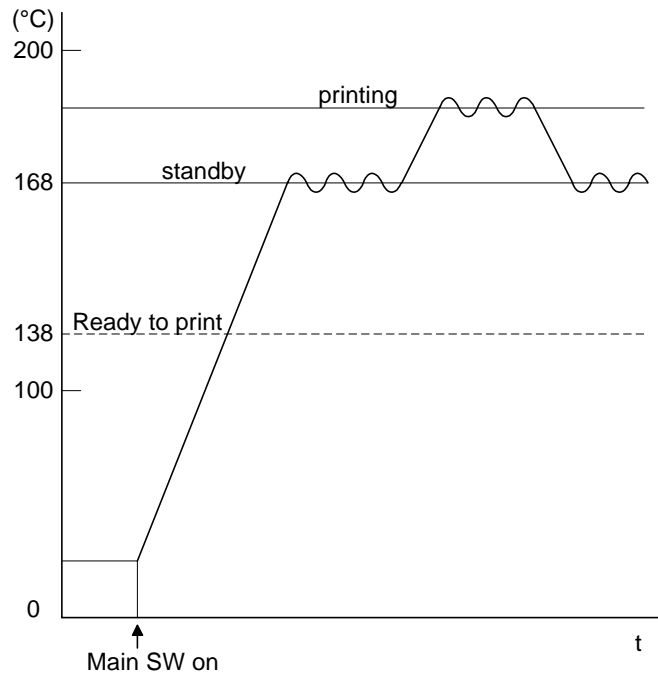

G056D502.WMF

When the main switch turns on, the CPU turns on the fusing lamp using the soft start process (this prevents the room lights from flickering). The lamp stays on until the thermistor detects the standby temperature. Then the CPU maintains this temperature using on-off control. To start printing, the CPU raises the temperature to the printing temperature.

The fusing temperature for each mode is as follows.

Condition	Temperature			Note
Ready to print	138 °C			The machine can start to print any time.
Standby mode	168 °C			On-off control
Printing	Print start ~ 2 minutes	2 min. ~ 4 min.	4 min ~	On-off control
Tray	170 °C	165 °C	160 °C	
By-pass (Envelopes)	180 °C	180 °C	180 °C	
By-pass (Post Cards)	185 °C	185 °C	185 °C	
By-pass (Others)	170 °C	165 °C	160 °C	
Envelope Feeder	180 °C	180 °C	180 °C	
Thick Paper	185 °C	185 °C	185 °C	

Detailed Descriptions

To change between on/off control and phase control: Engine Service Mode - Fusing control

**Overheat protection**

- If the hot roller temperature becomes greater than 240 °C, the CPU cuts off the power to the fusing lamp. At this time, SC543 will be generated.
- If the thermistor overheat protection fails, there is a thermostat in series with the common ground line of the fusing lamp. If the temperature of the thermostat becomes greater than 210 °C, the thermostat opens, removing power from the fusing lamp. At this time, the machine stops operation.

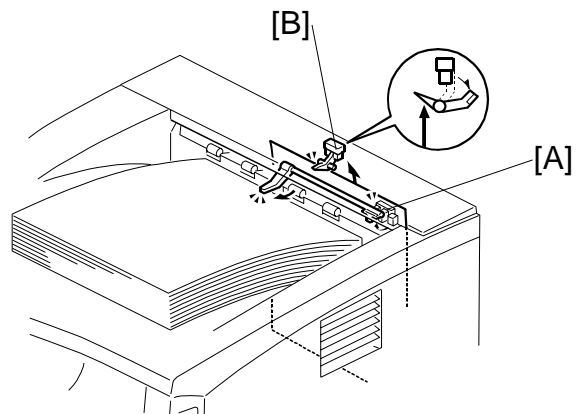
**6.5.7 PAPER EXIT**

[A]: Paper overflow detection sensor

[B]: Paper exit sensor

G058D601.WMF

- When the paper overflow detection sensor [A] is activated, the machine detects that the paper stack height has exceeded a certain limit and stops printing.
- The paper exit sensor [B] detects paper misfeeds.

## 6.5.8 ENERGY SAVER MODE

When the machine is not being used, the energy saver feature reduces power consumption by switching off the fusing lamp.

### *Entering Energy Saver Mode*

Energy saver mode starts after the machine has been idle for a certain time. This time is specified by the user; the following choices are available (press the Menu key on the operation panel, and access the System menu).

- Off (energy saver mode never activates)
- 5 minutes
- 15 minutes
- 30 minutes (default)
- 60 minutes

When the machine is in energy saver mode, the CPU turns off the fusing lamp. However, the +24V, +12V, and +5V lines are still active.

### *Leaving Energy Saver Mode*

The machine leaves energy saver mode when one of the following happens.

- Print command received from the PC
- Any cover opened and closed
- Any operation panel keys pressed

## 6.6 CONTROLLER FUNCTIONS

### 6.6.1 METER-CHARGE MODE

#### *Meter-charge Counter Display*

When the meter-charge mode (printer engine service mode) is switched on, the meter-charge counter menu is the first item shown on the user menu. (The “Sample Print” menu appears first when the meter-charge mode is switched off.)

Menu: Counter
------------------

#### *PM Warning Display*

When the meter-charge mode (printer engine service mode) is switched on, “Replace Maintenance Kit” will not be displayed at 90k prints.

**NOTE:** The default setting for this machine is meter-charge mode off.

Item	Meter-charge On	Meter-charge Off	Remarks
Meter-charge counter	Shown as the first item in the user menu	Not shown	User menu
PM Warning	Not shown	“Replace Maintenance Kit” displayed at 90k prints	
PM	Service	Customer	
PM Counter	Reset manually	Automatically reset when the fusing unit is replaced using the maintenance kit	Printer engine service mode “PM counter”

The meter-charge counter is not the same as the PM counter. This is because, in the following cases, the meter-charge counter does not count up.

- Blank rear side during duplex printing
- Blank page when using the “Cover Page” or “Two in One” features
- Service reports

**NOTE:** The meter-charge counter cannot be reset.

### 6.6.2 SAMPLE PRINT

This feature is formally known as “Proof Print”. This function gives users a chance to check the print results before starting a multiple-set print run.

- The size of the hard disk partition for the sample print feature is 5.4 GB. This partition is also used by the collation and locked print features.
- The partition can hold up to 30 files, including files stored using locked print.
- The maximum number of pages is 1,000, including jobs using locked print and collation.

**NOTE:** Sample print requires the installation of an optional hard disk.

### 6.6.3 LOCKED PRINT

Using this feature, the print job is stored in the machine but will not be printed until the user inputs an ID at the machine's operation panel. This ID must match the ID that was input with the printer driver.

- Stored data is automatically deleted after it is printed.
- Stored data can be manually deleted at the operation panel.
- The hard disk can hold up to 30 files, including files stored using sample print.
- The maximum number of pages is 1,000, including jobs using sample print and collation.
- Locked print uses the same hard disk partition as sample print and collation, which is 5.4 GB.

**NOTE:** Locked print requires the installation of an optional hard disk.

### 6.6.4 PAPER SOURCE SELECTION

#### *Tray Priority (Auto Tray Select)*

The Tray Priority setting determines the start of the tray search when the user selects "Auto Tray Select" with the driver.

The machine searches for a paper tray with the specified paper size and type.

When no tray contains paper that matches the paper size and type specified by the driver, the controller stops printing until the user loads the correct paper.

The Tray Priority setting can be specified using the Paper Input menu of the user tools.

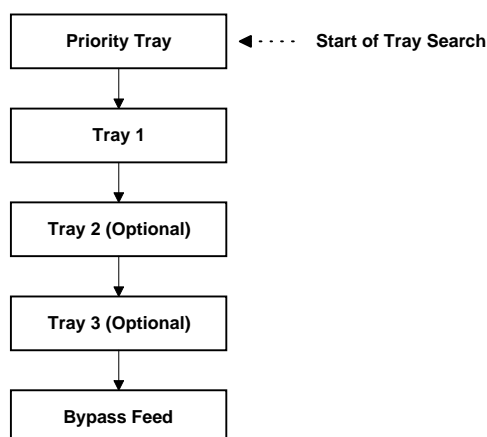

G058D521.WMF

Detailed  
Descriptions

#### *Tray Lock*

If Tray Lock is enabled for a tray, the controller skips the "locked" tray in the tray search process.

**NOTE:** In this machine, each paper source can be "locked", including the by-pass feeder. If all paper sources are locked and "Auto Tray Select" is specified from the driver, the machine displays an error and stops printing.

#### *Manual Tray Select*

If the selected tray does not have the paper size and type specified by the driver, the controller stops printing until the user loads the correct paper.

### 6.6.5 AUTO CONTINUE

When this function is enabled, the machine continues printing even if there is no paper tray which matches the paper size and paper type specified by the driver. The machine searches for a paper tray in the following way.

**NOTE:** The default setting for this feature is 'disabled'.

#### ***Auto Tray Select***

When there is no paper tray that matches the paper size and type specified by the driver, the machine searches for any tray that has paper, and prints from the first tray it finds. The start of the tray search is the tray selected as the "Priority Tray."

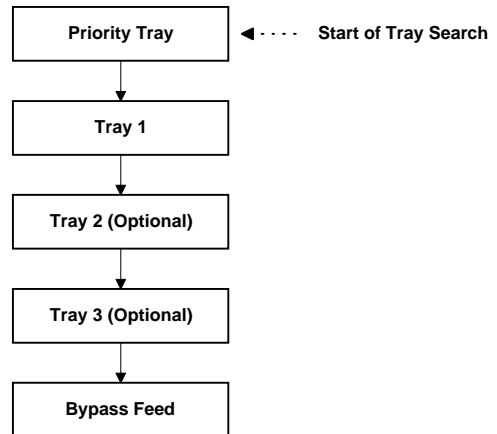

G058D521.WMF

#### ***Manual Tray Select***

The machine prints from the selected tray even if the paper size and type do not match the setting specified from the driver.



## 6.6.6 PAPER OUTPUT TRAY

The output tray can be selected using the “System” menu of the user tools. To select an output tray other than the standard tray, the one-bin shift tray or four-bin mailbox must be installed.

### ***Output Tray Selected***

- If the machine cannot print to the selected output tray, it prints to the standard tray.
- If paper overflow is detected at the selected output tray, the controller stops printing until the overflow detector goes off.

### ***Auto Tray Switching***

When “Auto Tray SW” is selected in the “System” menu of the user tools and “Printer Default” is specified as an output tray in the driver, the controller automatically sends the output to the lowest tray. When that tray fills up, the controller sends the output to the next lowest tray.

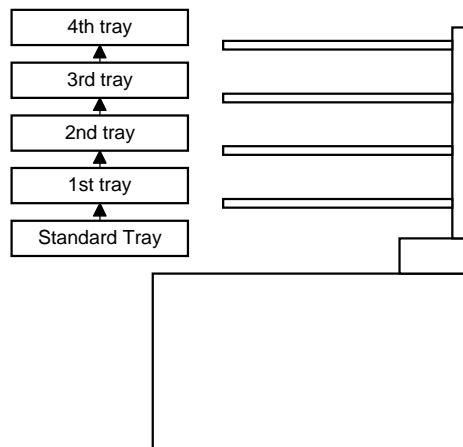

G058D522.WMF

- If a tray becomes full and paper is detected in the next tray, the machine displays an error and stops printing.
- If all trays become full (overflow detected in all trays), the machine displays an error and stops printing. This time, all paper must be removed.

## 6.7 NIB

### 6.7.1 BLOCK DIAGRAM

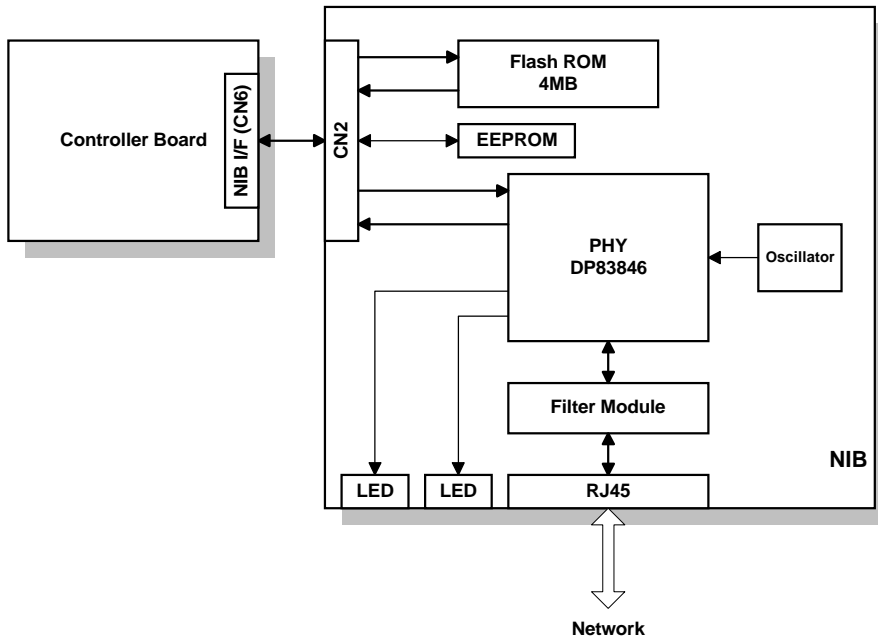

G056D505.WMF

- The Flash ROM contains the NIB firmware. The firmware can be upgraded using an IC card connected to the controller board.

### 6.7.2 LED INDICATORS

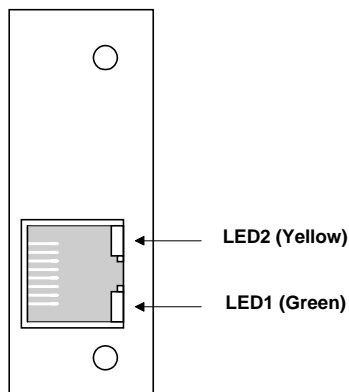

G056D506.WMF

Description	On	Off
LED1 (Green): Link status	Link success	Link failure
LED2 (Yellow): Data rate	100 Mbps	10 Mbps

## 6.8 IEEE1394 INTERFACE

### 6.8.1 SPECIFICATIONS

#### *Hardware Specification*

Interface: IEEE1394 (6 pins)  
 (non-power supply, cable power repeated-IEEE1394a-2000 compliant)  
 Ports: 2 ports  
 Data rates: 400Mbps/200Mbps/100Mbps

#### *System Requirements*

PC: IBM PC/AT with IEEE1394 port  
 OS: MS Windows 2000 upgraded with service pack 1  
 Cable length: 4.5m (15ft)

### 6.8.2 IEEE1394

IEEE1394, also known as FireWire (a name patented by Apple), is an easy-to-use peer-to-peer networking technology allowing speeds of up to 400 Mbps.

The current standard contains the following features, which are supported in most devices:

- Hot swapping (cables can be connected and disconnected while the computer and other devices are switched on)
- Peer-to-peer networking (no hub required)
- No terminator or device ID is required, unlike SCSI
- Automatic configuration of devices upon start-up, or “plug and play.”
- Real-time data transfer at 100, 200, and 400 Mbps
- Common connectors for different devices

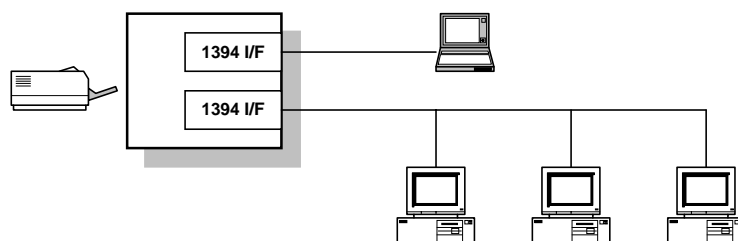

G056D513.WMF

The cable length is limited to 4.5 m (15ft). However, up to 16 cables and 63 devices can be connected to an IEEE1394 network.

IEEE1394 cables can be either 4-pin (data only) or 6-pin (data and power). IEEE1394 allows either 6-pin or 4-pin connectors. However, this machine only uses the 6-pin connectors. The machine has two 6-pin ports.

### 6.8.3 BLOCK DIAGRAM

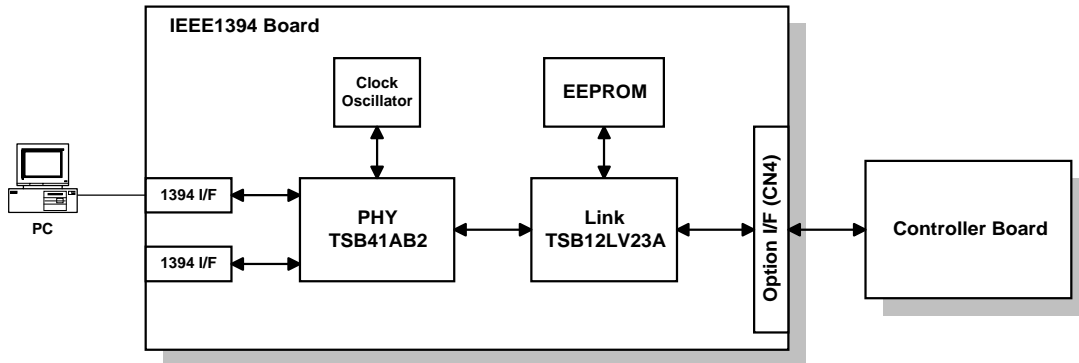

G056D508.WMF

- PHY: Physical layer control device
- Link: Link layer control device
- EEPROM: 256-byte ROM

### 6.8.4 PIN ASSIGNMENT

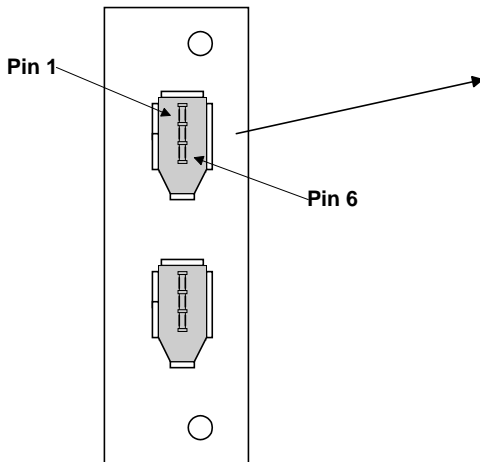

Pin assignment	
Pin 1	Pin 4
Pin 2	Pin 3
Pin 5	Pin 6

G056D514.WMF

Pin No.	Signal Description
1	Cable Power
2	GND
3	Receive strobe
4	Transmit data
5	Receive data
6	Transmit strobe

## 6.8.5 REMARKS ABOUT THIS INTERFACE KIT

Note the following points about this unit.

- The machine does not print reports specifically for IEEE1394. Just print the Configuration Page at installation to check that the machine recognizes the card.
- There is no spooler or print queue. If a computer tries to print over the IEEE1394 while the printer is busy, the IEEE1394 interface card inside the printer will return a busy signal.
- After starting a job using IEEE1394, do not switch the printer off until the job has been completed. Even though the printer may appear to be dead, it may be in the middle of an IEEE1394 protocol exchange with the computer.
- When using IEEE1394, it is not possible to check the printer status from the computer with a utility such as Printer Manager for Client.

## 6.8.6 TROUBLESHOOTING NOTES

If there are problems printing using the IEEE1394 interface, check the following.

- Is the computer using Windows 2000 with service pack 1?
- Has the interface card been replaced recently? Each card has an individual address, similar to the MAC address in an Ethernet card. If the card was changed, the driver cannot find the old card. The new card is another device and a new printer appears in Windows Control panel, and this must be configured in the same way as the printer that was replaced (the old printer icon in Windows Control Panel should be deleted) has to be reconfigured.
- Is there a loop somewhere in the network? An IEEE1394 network must be a chain or a branched chain. There can be no loops.
- Try to find out where in the chain the problem is occurring. Test the machine one-to-one with the computer to determine if the printer is defective (when the printer's interface cable is plugged in, the computer should see 'Printer Ready'; when the cable is disconnected, the computer should see 'Offline').

---

# SPECIFICATIONS

## 1. GENERAL SPECIFICATIONS

Printing Speed:	Maximum 26 pages per minute (A4/LT LEF) (20 pages: duplex printing)
Printer Languages:	PCL6/PCL5e PostScript 3 RPCS (Refined Printing Command Stream: an original Ricoh PDL) TIFF (rev 6.0 compatible)
Resolution:	1200 dpi (PCL6/PS3/RPCS) 600 dpi (PCL 6/PCL5e/PS3/RPCS) 300 dpi (PCL 5e/PS3)
Resident Fonts:	PCL: 35 Intellifonts 10 True Type fonts PS3: 136 fonts (24 Type 2 fonts, 112 Type 14 fonts)
Host Interfaces:	Bi-directional IEEE1284 parallel x 1: Standard Ethernet (100 Base-TX/10 Base-T): Standard for G058 IEEE1394: Optional for G056 (G058: Must remove NIB)
Network Protocols:	TCP/IP, IPX/SPX, NetBEUI, Apple Talk
First Print Speed:	6.5 s or less (A4/LT LEF, standard tray)
Warm-up Time	Less than 12 seconds (Less than 19 seconds from power on)
Print Paper Capacity:	Standard tray: 250 sheets Optional paper tray unit: 500 sheets (up to two paper tray units can be installed) Optional by-pass tray: 100 sheets
Print Paper Size:	Maximum: A3/11" x 17" Minimum: Standard tray: A5 LEF Optional paper tray: A5 LEF By-pass: A6/ 90 x 148 mm SEF  (Refer to "Supported Paper Sizes".)
Printing Paper Weight:	Standard tray: 60 to 105 g/m <sup>2</sup> (16 to 28 lb.) Optional paper tray: 60 to 105 g/m <sup>2</sup> (16 to 28 lb.) By-pass tray: 52 to 162 g/m <sup>2</sup> (14 to 43 lb.)
Output Paper Capacity:	Standard output tray: 250 sheets Optional 1-bin shift tray: 250 sheets Optional 4-bin mailbox: 200 sheets total

Memory: Standard 32 MB, up to 96 MB with optional DIMM  
 Power Source: 120 V, 60 Hz: More than 10 A (for North America)  
 220 V - 240 V, 50/60 Hz: More than 6.0 A (for Europe)  
 Power Consumption:

	<b>120V</b>	<b>230V</b>
Maximum	940 W or less	940 W or less
Printing	650 W or less	650 W or less
Energy Saver	22 W or less	22 W or less

Noise Emission:

	<b>Mainframe Only</b>	<b>Full System</b>
Printing	64 dB or less	68 dB or less
Stand-by	40 dB or less	40 dB or less

**NOTE:** The above measurements were made in accordance with ISO 9296 at the operator position.

Dimensions (W x D x H): 468 x 437 x 305 mm

Weight: Less than 18 kg

## 1.1 SUPPORTED PAPER SIZES

Paper	Size (W x L)	Paper Trays Main Unit/Option		By-pass Tray	Env. Feeder	Duplex
		US	Eur/Asia			
A3	297 x 420 mm	Y <sup>#</sup> /Y <sup>#</sup>	Y/Y	Y <sup>#</sup>	N	Y
B4	257 x 364 mm	Y <sup>#</sup> /Y <sup>#</sup>	Y <sup>#</sup> /Y <sup>#</sup>	Y <sup>#</sup>	N	Y
A4 SEF	210 x 297 mm	Y <sup>#</sup> /Y <sup>#</sup>	Y/Y	Y <sup>#</sup>	N	Y
A4 LEF	297 x 210 mm	Y/Y	Y/Y	Y <sup>#</sup>	Y	Y
B5 SEF	182 x 257 mm	Y <sup>#</sup> /Y <sup>#</sup>	Y <sup>#</sup> /Y <sup>#</sup>	Y <sup>#</sup>	N	Y
B5 LEF	257 x 182 mm	Y <sup>#</sup> /Y <sup>#</sup>	Y <sup>#</sup> /Y <sup>#</sup>	Y <sup>#</sup>	N	Y
A5 SEF	148 x 210 mm	N	N	Y <sup>#</sup>	N	N
A5 LEF	210 x 148 mm	Y <sup>#</sup> /Y <sup>#</sup>	Y/Y <sup>#</sup>	Y <sup>#</sup>	N	Y
B6 SEF	128 x 182 mm	N	N	Y <sup>C</sup>	N	N
B6 LEF	182 x 128 mm	N	N	N	N	N
A6 SEF	105 x 148 mm	N	N	Y <sup>C</sup>	N	N
Ledger	11 x 17"	Y/Y	Y <sup>#</sup> /Y <sup>#</sup>	Y <sup>#</sup>	N	Y
Legal	8.5 x 14"	Y/Y	Y <sup>#</sup> /Y <sup>#</sup>	Y <sup>#</sup>	N	Y
Letter SEF	8.5 x 11"	Y/Y	Y/Y	Y <sup>#</sup>	N	Y
Letter LEF	11 x 8.5"	Y/Y	Y/Y	Y <sup>#</sup>	N	Y
Half Letter SEF	5.5 x 8.5"	N	N	Y <sup>#</sup>	N	N
Half Letter LEF	8.5 x 5.5"	N	N	N	N	N
Executive SEF	7.25 x 10.5"	N/Y <sup>#</sup>	N/Y <sup>#</sup>	Y <sup>#</sup>	N	N
Executive LEF	10.5 x 7.25"	Y <sup>#</sup> /Y <sup>#</sup>	Y <sup>#</sup> /Y <sup>#</sup>	Y <sup>#</sup>	N	Y
F	8 x 13"	Y <sup>#</sup> /Y <sup>#</sup>	Y <sup>#</sup> /Y <sup>#</sup>	Y <sup>#</sup>	N	Y
Foolscap	8.5 x 13"	Y/Y <sup>#</sup>	Y <sup>#</sup> /Y <sup>#</sup>	Y <sup>#</sup>	N	Y
Folio	8.25 x 13"	Y <sup>#</sup> /Y <sup>#</sup>	Y <sup>#</sup> /Y <sup>#</sup>	Y <sup>#</sup>	N	Y
Com10 Env.	4.125 x 9.5"	N	N	Y <sup>#</sup>	Y <sup>#</sup>	N
Monarch Env.	3.875 x 7.5"	N	N	Y <sup>#</sup>	Y <sup>#</sup>	N
C6 Env.	114 x 162 mm	N	N	Y <sup>#</sup>	Y <sup>#</sup>	N
C5 Env.	162 x 229 mm	N	N	Y <sup>#</sup>	Y <sup>#</sup>	N
DL Env.	110 x 220 mm	N	N	Y <sup>#</sup>	Y <sup>#</sup>	N
8K	267 x 390 mm	N/Y <sup>#</sup>	N/Y <sup>#</sup>	Y <sup>#</sup>	N	Y
16K SEF	195 x 267 mm	N/Y <sup>#</sup>	N/Y <sup>#</sup>	Y <sup>#</sup>	N	Y
16K LEF	267 x 195 mm	N/Y <sup>#</sup>	N/Y <sup>#</sup>	Y <sup>#</sup>	N	Y
Custom	Minimum: 90 x 148 mm Maximum: 297 x 432 mm	N/Y <sup>C</sup>	N/Y <sup>C</sup>	Y <sup>C</sup>	N	N

### Remarks:

Y	Supported. The paper size sensor detects the paper size.
Y <sup>#</sup>	Supported. The user has to select the correct paper size for the tray.
Y <sup>C</sup>	Supported. The user has to enter the width and length of the paper.
N	Not supported.



## 2. SOFTWARE ACCESSORIES

The printer drivers and utility software are provided on one CD-ROM. An auto-run installer allows you to select which components to install.

### 2.1 PRINTER DRIVERS

Printer Language	Windows 95/98/ME	Windows NT4.0	Windows 2000	Macintosh
PCL 6	Yes	Yes	Yes	No
PCL 5e	Yes	Yes	Yes	No
PS3	Yes	Yes	Yes	Yes
RPCS	Yes	Yes	Yes	No

- NOTE:**
- 1) The printer drivers for Windows NT 4.0 are only for the Intel x86 platform. There is no Windows NT 4.0 printer driver for the PowerPC, Alpha, or MIPS platforms.
  - 2) The PS3 drivers are all genuine AdobePS drivers, except for Windows 2000, which uses Microsoft PS. A PPD file for each operating system is provided with the driver.
  - 3) The PS3 driver for Macintosh supports Mac OS 7.6 or later versions.

### 2.2 UTILITY SOFTWARE

Software	Description
Agfa Font Manager (Win3.1x, 95/98, NT4)	A font management utility with screen fonts for the printer.
Aficio Manager for Admin (Win 95/98, NT4)	A printer management utility for network administrators. NIB setup utilities are also available.
Aficio Manager for Client (Win95/98, NT4)	A printer management utility for client users.
Multidirect Print (Win95/98, 2000, NT4, )	A utility for peer-to-peer printing over a NetBEUI or TCP/IP network.
Port Navi (Win95/98, 2000, NT4)	A peer to peer print utility over a TCP/IP network. This provides the parallel printing and recovery printing features.
Printer Utility for Mac	This software provides several convenient functions for printing from Macintosh clients.

### 3. MACHINE CONFIGURATION

#### 3.1 SYSTEM COMPONENTS

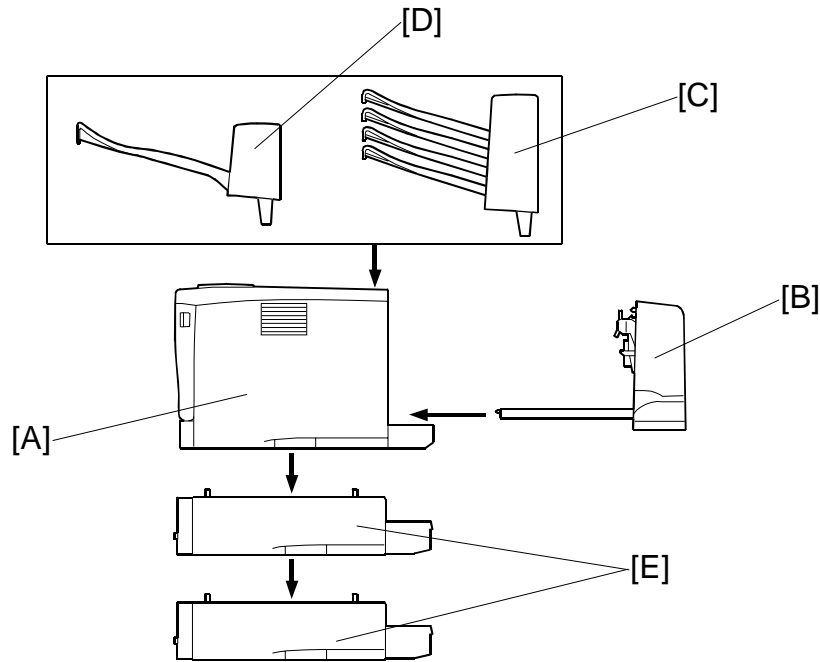

G058V107.WMF

Item	Machine Code	No.	Remarks
Main Unit	G058 G056	A	G058: Includes the NIC option as standard
<b>Option</b>			
Duplex Unit	G552	B	
4-bin Mailbox	G553	C	
1-bin Shift Tray	G554	D	
Paper Tray Unit	G555	E	Up to two tray units can be installed.
Envelope Feeder	G556	E	When two paper tray units are installed, it must be installed in the upper unit.
<b>Internal Option</b>			
NIB	G573		Standard component for G058
IEEE1394	G561		To install in the G058, remove the NIB first.
HDD	G575		
Memory 64 MB	G579		
<b>Others</b>			
Maintenance Kit	G770		

**NOTE:** 1) All the above items are user installable.  
 2) The NIB and the IEEE1394 board cannot be installed at the same time.  
 To install the IEEE1394 in the G058, remove the NIB first.

Spec.

## 4. OPTIONAL EQUIPMENT

### 4.1 PAPER TRAY UNIT

Print Paper Size:	Maximum: A3/11" x 17" Minimum: A5 LEF
Print Paper Weight:	60 to 105 g/m <sup>2</sup> (16 to 28 lb.)
Tray Capacity:	500 sheets (80 g/m <sup>2</sup> , 20 lb.) Two units can be installed.
Paper Feed System:	Feed roller and friction pad
Paper Height Detection:	4 steps (100%, 90%, 50%, 10%)
Power Source:	DC 24V, 5V (from the main unit)
Power Consumption:	15 W
Dimensions (W x D x H):	468 x 410 x 130 mm
Weight	5.6 kg

### 4.2 ENVELOPE FEEDER

Print Paper Size:	Com#10, Monarch, C6, DL, C5
Tray Capacity:	60, or up to the level of the maximum stack indication (52 mm)
Paper Feed System:	Feed roller and friction pad
Paper Height Detection:	None
Weight	1.9 kg

### 4.3 DUPLEX UNIT

Print Paper Size:	Maximum: A3/11" x 17" Minimum: A5 SEF
Print Paper Weight:	64 to 105 g/m <sup>2</sup> (18 to 28 lb.)
Paper Capacity:	1 sheet
Power Source:	DC 24V, 5V (from the main unit)
Power Consumption:	35 W
Dimensions (W x D x H):	419 x 115 x 257 mm (when installed in the machine)
Weight	6 kg

#### **4.4 FOUR-BIN MAILBOX**

Number of Trays	4 trays
Tray Capacity:	50 sheets (80 g/m <sup>2</sup> , 20 lb.)
Paper Size for Trays:	Maximum: A3/11" x 17" Minimum: A5 LEF
Print Paper Weight:	60 to 105 g/m <sup>2</sup> (16 to 28 lb.)
Power Source:	DC 24V, 5V (from the main unit)
Power Consumption:	15 W
Dimensions (W x D x H):	462 x 391 x 285 mm (when installed in the machine)
Weight	5.3 kg

#### **4.5 ONE-BIN SHIFT TRAY**

Print Paper Size:	Maximum: A3/11" x 17" Minimum: A5 LEF
Print Paper Weight:	60 to 105 g/m <sup>2</sup> (16 to 28 lb.)
Tray Capacity:	250 sheets (80 g/m <sup>2</sup> , 20 lb.)
Power Source:	DC 24V, 5V (from the main unit)
Power Consumption:	12 W
Dimensions (W x D x H):	462 x 393 x 160 mm (when installed in the machine)
Weight	2.6 kg

# PRINTER (G056/G058) POINT TO POINT CIRCUIT DIAGRAM

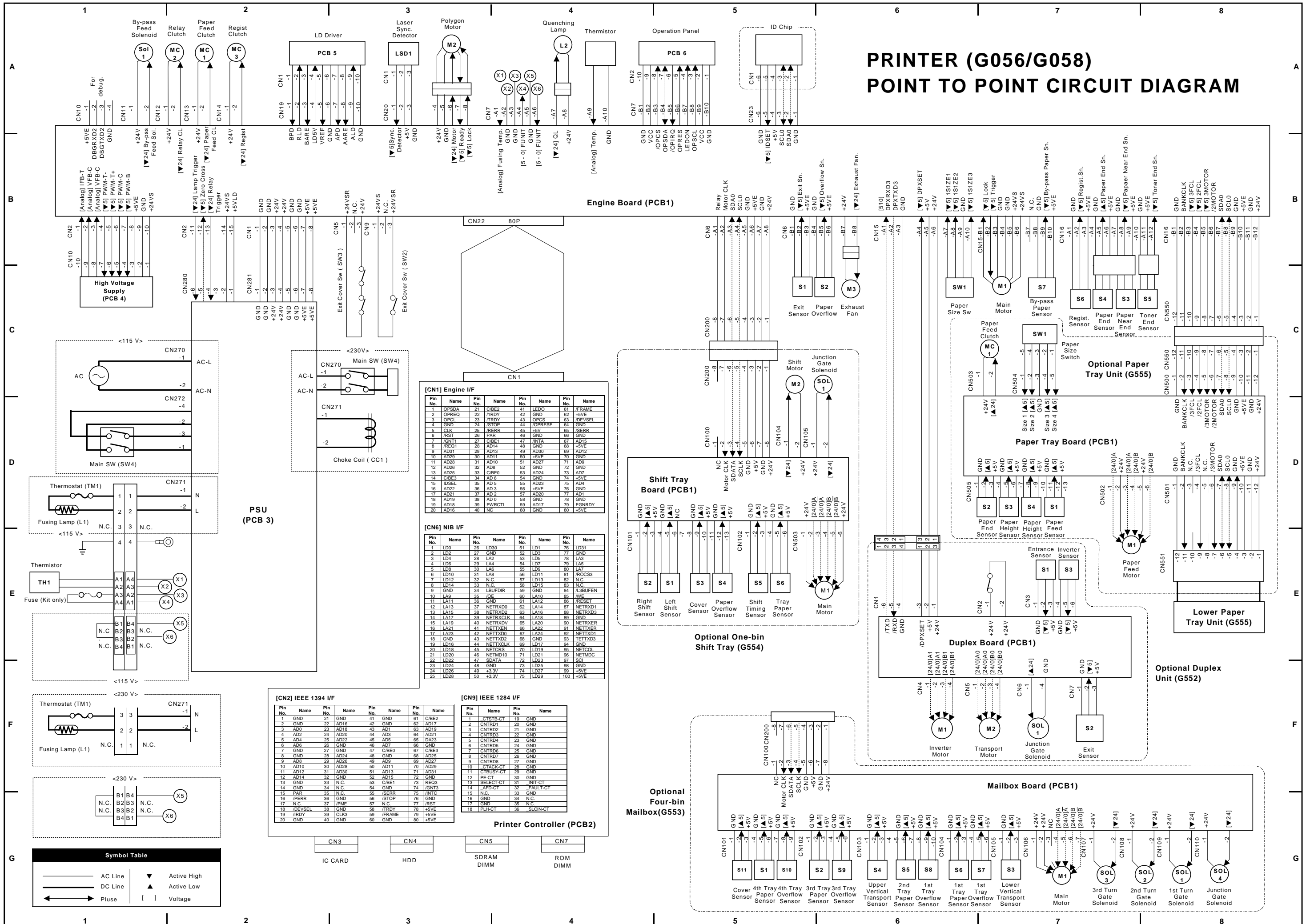

**[CN1] Engine I/F**

Pin No.	Name	Pin No.	Name	Pin No.	Name	Pin No.	Name
1	OPSDA	21	C/BE2	41	LEDO	61	/FRAME
2	OPREQ	22	/TRDY	42	GND	62	+5VE
3	OPCL	23	/TRDY	43	OPCS	63	/DE/SEL
4	GND	24	/STOP	44	/OPRESE	64	GND
5	CLK	25	/BERR	45	+5V	65	/SERR
6	/RST	26	PAR	46	GND	66	GND
7	/REQ1	27	C/BE1	47	/INTA	67	AD15
8	/REQ1	28	AD14	48	GND	68	+5VE
9	AD31	29	AD13	49	AD30	69	AD12
10	AD39	30	AD11	50	+5VE	70	GND
11	AD28	31	AD10	51	AD27	71	AD9
12	AD26	32	AD8	52	GND	72	GND
13	AD25	33	C/BE0	53	AD24	73	AD7
14	C/BE3	34	AD9	54	GND	74	+5VE
15	IDSEL	35	AD5	55	AD23	75	AD4
16	AD22	36	AD3	56	+5VE	76	GND
17	AD21	37	AD2	57	AD20	77	AD1
18	AD19	38	AD0	58	GND	78	GND
19	AD18	39	PWRCTL	59	AD17	79	EGNRDY
20	AD16	40	NC	60	GND	80	+5VE

**[CN6] NIB I/F**

Pin No.	Name	Pin No.	Name	Pin No.	Name	Pin No.	Name
1	LD0	28	LD30	51	LD1	76	LD31
2	LD2	27	GND	52	LD3	77	GND
3	LD4	28	LA2	53	LD5	78	LA3
4	LD6	29	LA4	54	LD7	79	LA5
5	LD8	30	LA6	55	LD9	80	LA7
6	LD10	31	LA8	56	LD11	81	/ROCS3
7	LD12	32	N.C.	57	LD13	82	N.C.
8	LD14	33	N.C.	58	LD15	83	N.C.
9	GND	34	LB/DFDR	59	GND	84	A3/BUFFEN
10	LA9	35	OE	60	LA10	85	A/VE
11	LA11	36	GND	61	LA12	86	A/RESET
12	LA13	37	NETRXD0	62	LA14	87	NETRXD1
13	LA15	38	NETRXD2	63	LA16	88	NETRXD3
14	LA17	39	NETRXCLK	64	LA18	89	GND
15	LA19	40	NETRXDY	65	LA20	90	NETRXER
16	LA21	41	NETXEN	66	LA22	91	NETTXER
17	LA23	42	NETXDD	67	LA24	92	NETTXD1
18	GND	43	NETXDD2	68	GND	93	NETTXD3
19	LD16	44	NETXCLK	69	LD17	94	GND
20	LD18	45	NETCRS	70	LD19	95	NETCOL
21	LD20	46	NETMD10	71	LD21	96	NETMDC
22	LD22	47	SDATA	72	LD23	97	SCI
23	LD24	48	GND	73	LD25	98	GND
24	LD26	49	+3.3V	74	LD27	99	+5VE
25	LD28	50	+3.3V	75	LD29	100	+5VE

**[CN2] IEEE 1394 I/F**

Pin No.	Name	Pin No.	Name	Pin No.	Name	Pin No.	Name
1	GND	21	GND	41	GND	61	C/BE2
2	GND	22	AD16	42	GND	62	AD17
3	AD0	23	AD19	43	AD1	63	AD19
4	AD2	24	AD20	44	AD3	64	AD21
5	AD4	25	AD22	45	AD5	65	DA33
6	AD6	26	GND	46	AD7	66	GND
7	GND	27	GND	47	C/BE0	67	C/BE3
8	GND	28	AD24	48	GND	68	AD25
9	AD8	29	AD26	49	AD9	69	AD27
10	AD10	30	AD28	50	AD11	70	AD29
11	AD12	31	AD30	51	AD13	71	AD31
12	AD14	32	GND	52	AD15	72	GND
13	GND	33	N.C.	53	C/BE1	73	REG3
14	GND	34	N.C.	54	GND	74	/GNTR3
15	PAR	35	N.C.	55	/SERR	75	/INTC
16	/PERR	36	GND	56	/STOP	76	GND
17	N.C.	37	/PME	57	N.C.	77	/RST
18	/DE/SEL	38	GND	58	/TRDY	78	+5VE
19	/RDY	39	CLK3	59	/FRAME	79	+5VE
20	GND	40	GND	60	GND	80	+5VE

**Printer Controller (PCB2)**

Pin No.	Name	Pin No.	Name	Pin No.	Name
1	CTSTB-CT	19	GND		
2	CNTRD1	20	GND		
3	CNTRD2	21	GND		
4	CNTRD3	22	GND		
5	CNTRD4	23	GND		
6	CNTRD5	24	GND		
7	CNTRD6	25	GND		
8	CNTRD7	26	GND		
9	CNTRD8	27	GND		
10	CTACK-CT	28	GND		
11	CTBUSY-CT	29	GND		
12	PE-CT	30	GND		
13	SELECT-CT	31	INIT-CT		
14	AFD-CT	32	FAULT-CT		
15	N.C.	33	GND		
16	GND	34	N.C.		
17	GND	35	N.C.		
18	PLH-CT	36	SLCIN-CT		

**Symbol Table**

	AC Line		Active High
	DC Line		Active Low
	Pluse		Voltage

# ELECTRICAL COMPONENT LAYOUT (1/3)

Symbol	Name	Index No.	P to P
<b>Motors</b>			
M1	Main	19	C7
M2	Polygonal Mirror	26	A3
M3	Exhaust Fan	24	C6
<b>Magnetic Clutches</b>			
MC1	Paper Feed	12	A2
MC2	Relay	16	A2
MC3	Registration	17	A2
<b>Switches</b>			
SW1	Paper Size	13	C6
SW2	Front Cover	28	C3
SW3	Rear Cover	2	C3
SW4	Main	7	C3, D1
<b>Sensors</b>			
S1	Paper Exit	1	C5
S2	Paper Overflow	3	C6
S3	Paper Near End	8	C7
S4	Paper End	9	C7
S5	Toner End	10	C8
S6	Registration	11	C7
S7	By-pass paper	14	C7
<b>PCBs</b>			
PCB1	Engine	18	B4
PCB2	Printer controller	20	G4
PCB3	PSU (Power Supply Unit)	4	D2
PCB4	High Voltage Supply	5	C1
PCB5	LDD (Laser Diode Driver)	27	A3
PCB6	Operation Panel	29	A5
<b>Solenoids</b>			
Sol1	By-pass feed	15	A1
<b>Lamps</b>			
L1	Fusing	21	D1, F1
L2	Quenching	30	A4
<b>Others</b>			
TM1	Thermostat	22	D1, F1
TH1	Thermistor	23	E1
LSD1	Laser Synchronization Detector	25	A3
CC1	Choke Coil (230V machine only)	6	D3

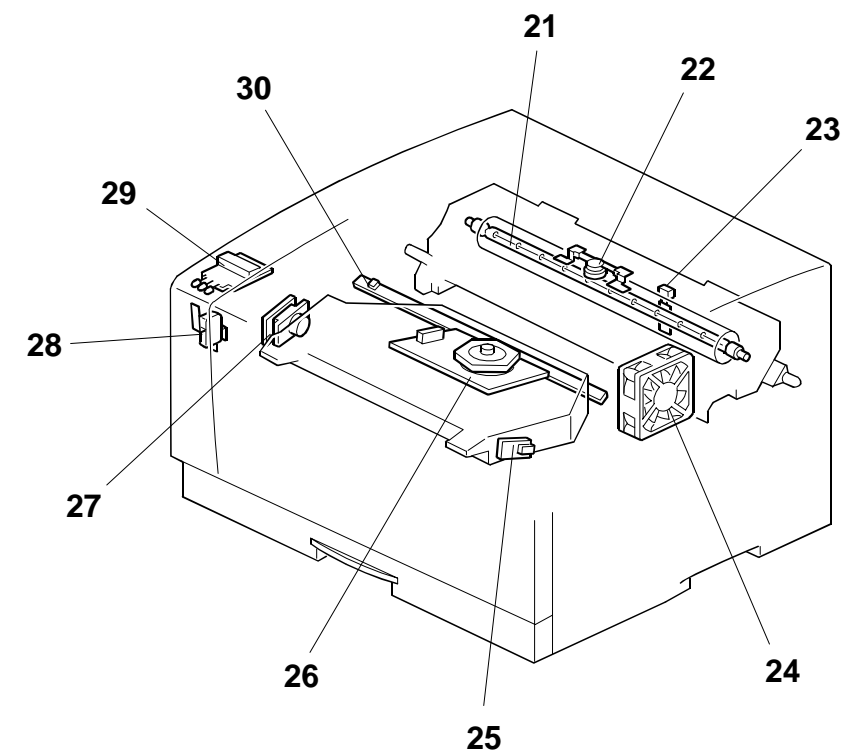
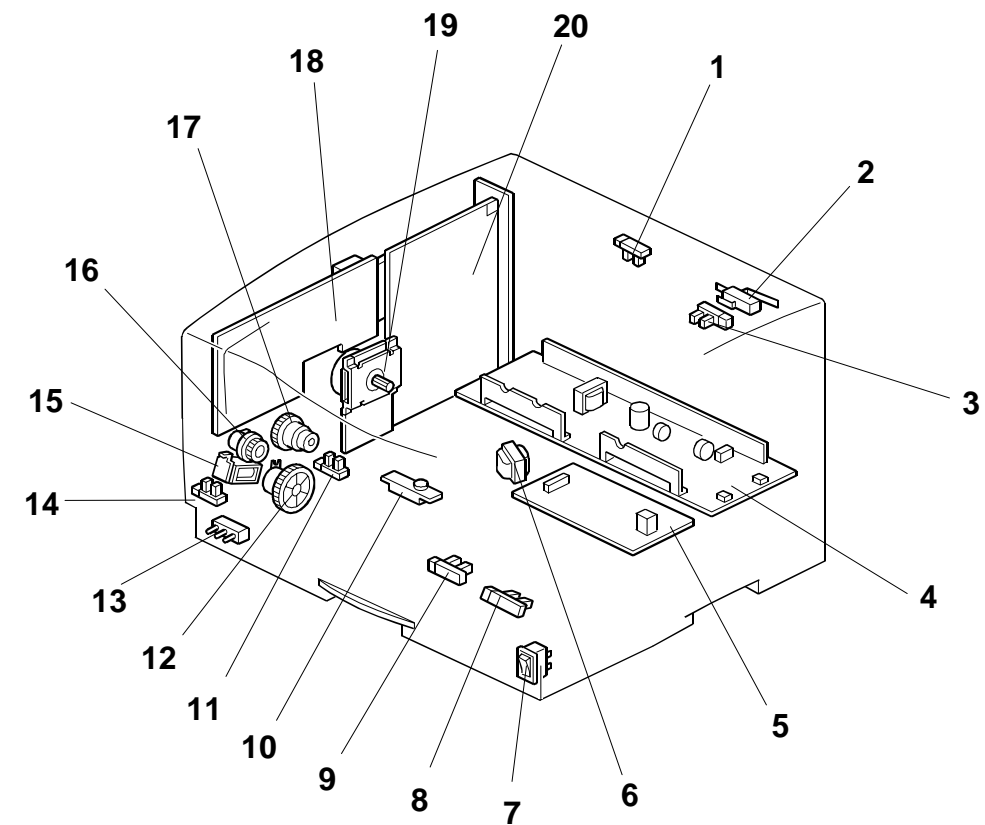

# ELECTRICAL COMPONENT LAYOUT (2/3)

## Duplex Unit (G552)-1

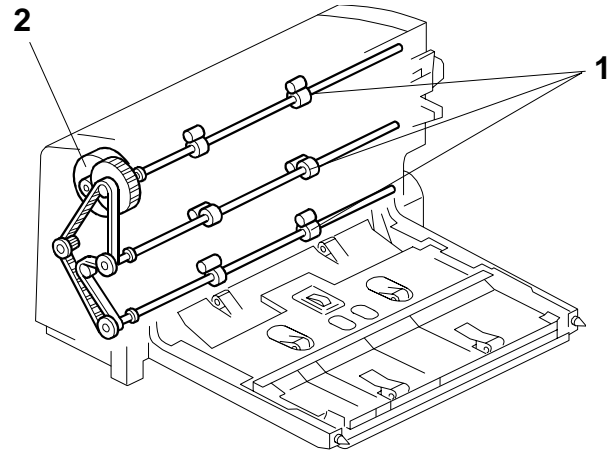

## Duplex Unit (G552)-2

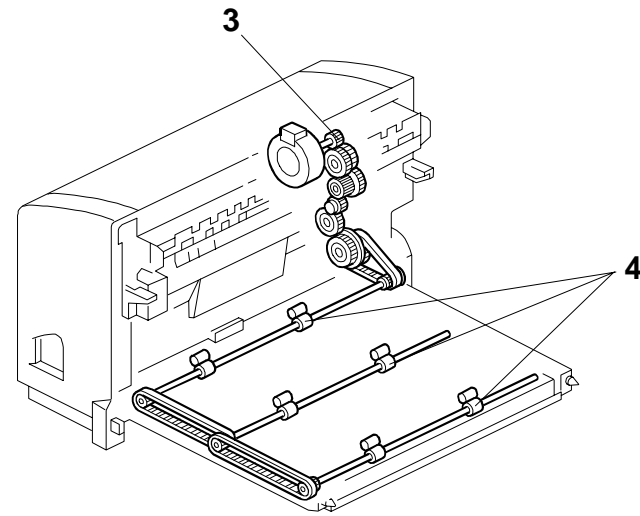

## Duplex Unit (G552)-3

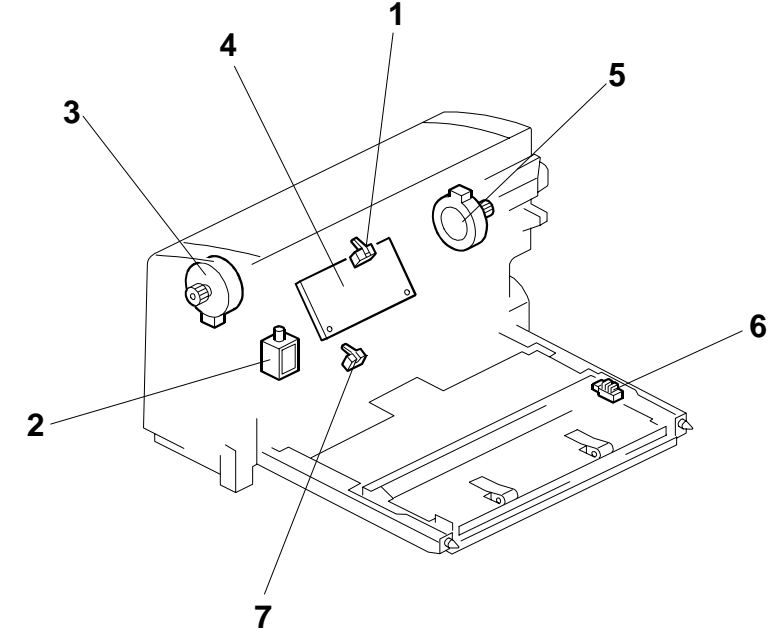

## Four-bin Mailbox (G553)

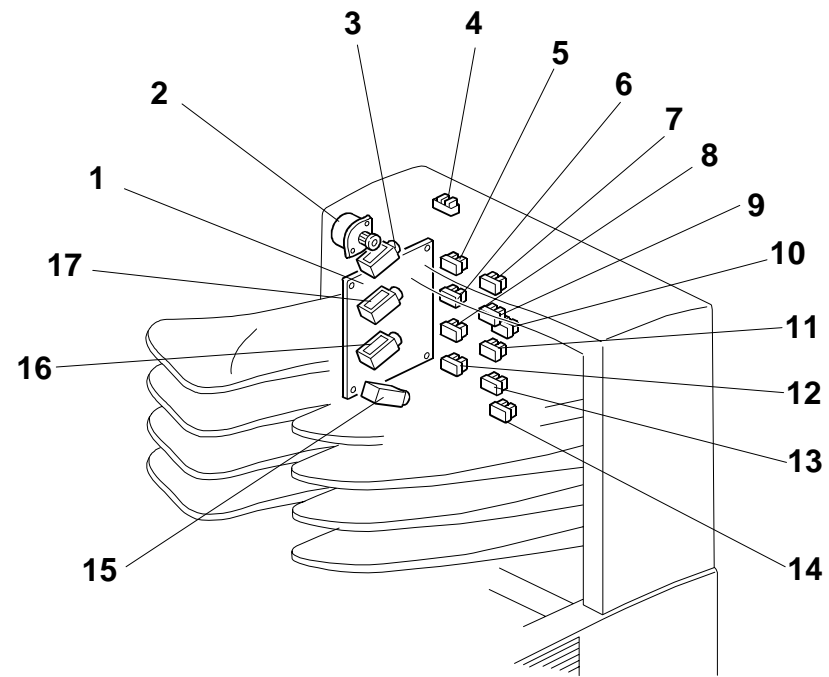

## One-bin Shift Tray (G554)

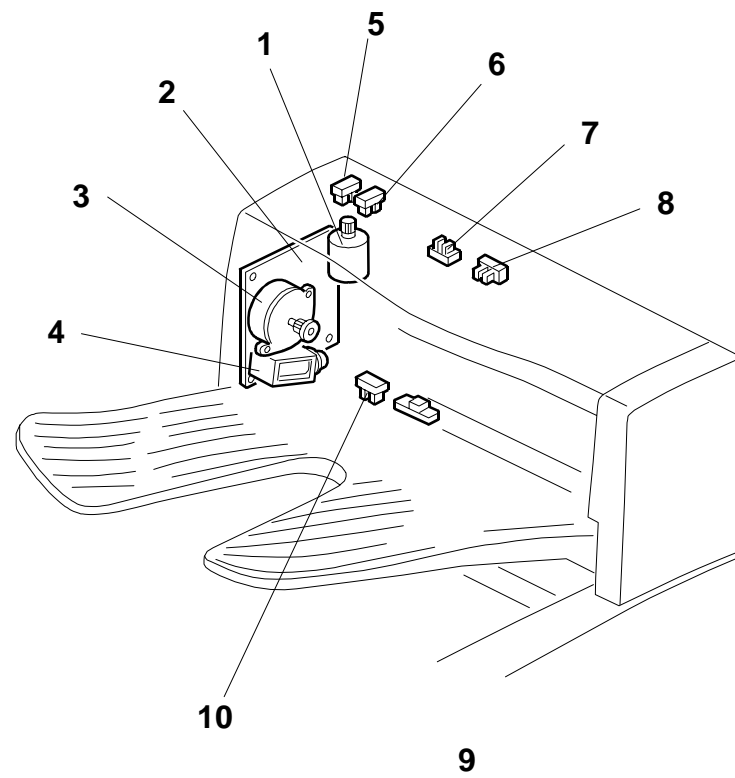

## Paper Tray Unit (G555)

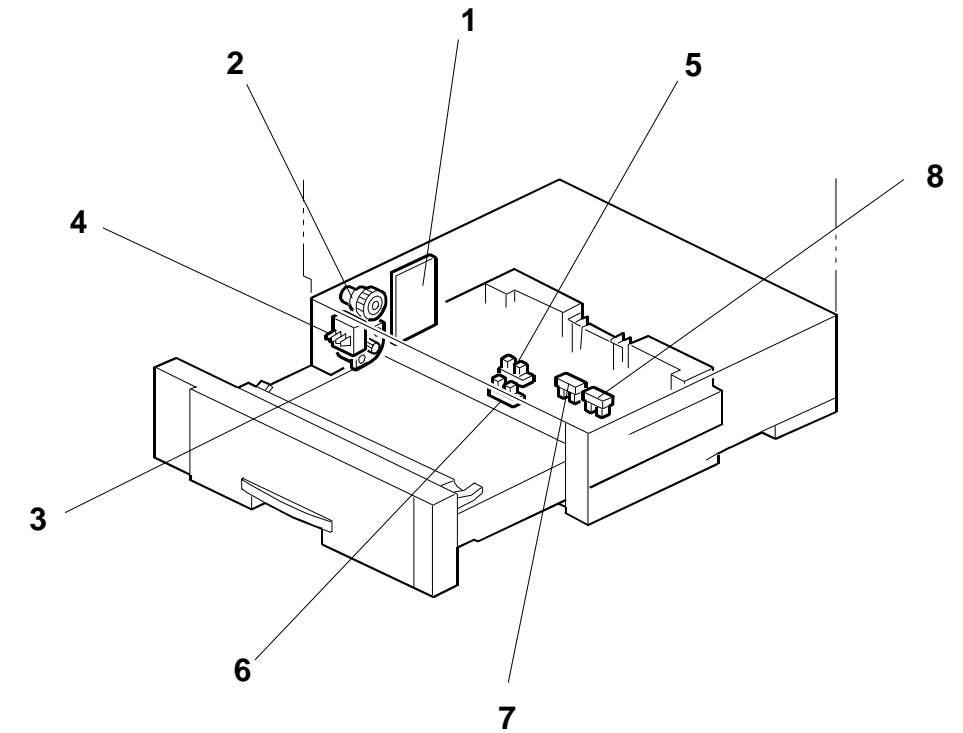

## ELECTRICAL COMPONENT LAYOUT (3/3)

### Duplex Unit (G552)

Symbol	Name	Index No.	P to P
<b>Motors</b>			
M1	Inverter	3	F6
M2	Transport	5	F7
<b>Sensors</b>			
S1	Entrance	1	E7
S2	Exit	6	F7
S3	Inverter	7	E7
<b>Solenoids</b>			
SOL1	Inverter gate	2	F7
<b>PCBs</b>			
PCB1	Duplex board	4	E7

### One-bin Shift Tray (G554)

Symbols	Name	Index No.	P to P
<b>Motors</b>			
M1	Main	3	E6
M2	Shift	1	C5
<b>Sensors</b>			
S1	Left shift	5	E5
S2	Right shift	6	E4
S3	Upper cover	7	E5
S4	Paper overflow	8	E5
S5	Shift timing	9	E5
S6	Tray paper	10	E5
<b>Solenoids</b>			
SOL1	Junction gate solenoid	4	C6
<b>PCBs</b>			
PCB1	Shift tray board	2	D5

### Four-bin Mailbox (G553)

Symbols	Name	Index No.	P to P
<b>Motors</b>			
M1	Main	2	G7
<b>Sensors</b>			
S1	4th tray Paper	5	G5
S2	3rd tray Paper	6	G6
S3	Lower vertical transport	14	G7
S4	Upper vertical transport	10	G6
S5	2nd tray paper	8	G6
S6	1st tray paper	12	G6
S7	1st tray overflow	13	G7
S8	2nd tray overflow	11	G6
S9	3rd tray overflow	9	G6
S10	4th tray Overflow	7	G5
S11	Cover	4	G5
<b>Solenoids</b>			
SOL1	1st turn gate solenoid	16	G8
SOL2	2nd turn gate solenoid	1	G8
SOL3	3rd turn gate solenoid	3	G7
SOL4	Junction gate solenoid	15	G8
<b>PCBs</b>			
PCB1	Mailbox board	17	G7

### Paper Tray Unit (G555)

Symbol	Name	Index No.	P to P
<b>Motor</b>			
M1	Paper feed motor	3	E7
<b>Sensors</b>			
S1	Paper feed sensor	6	D7
S2	Paper end sensor	5	D7
S3, S4	Paper height sensor	7, 8	D7
<b>Switch</b>			
SW1	Paper size switch	4	C7
<b>Clutch</b>			
MC1	Paper feed clutch	2	C7
<b>PCB</b>			
PCB1	Paper tray board	1	D7